

1	DD	6-18-15
2	HEALTH COMMENTS	09/29/15
NO.	REVISIONS/ISSUES	DATE:

A New Facility For:
OPTIMUM PERSONAL CARE
SUGAR LAND, TX

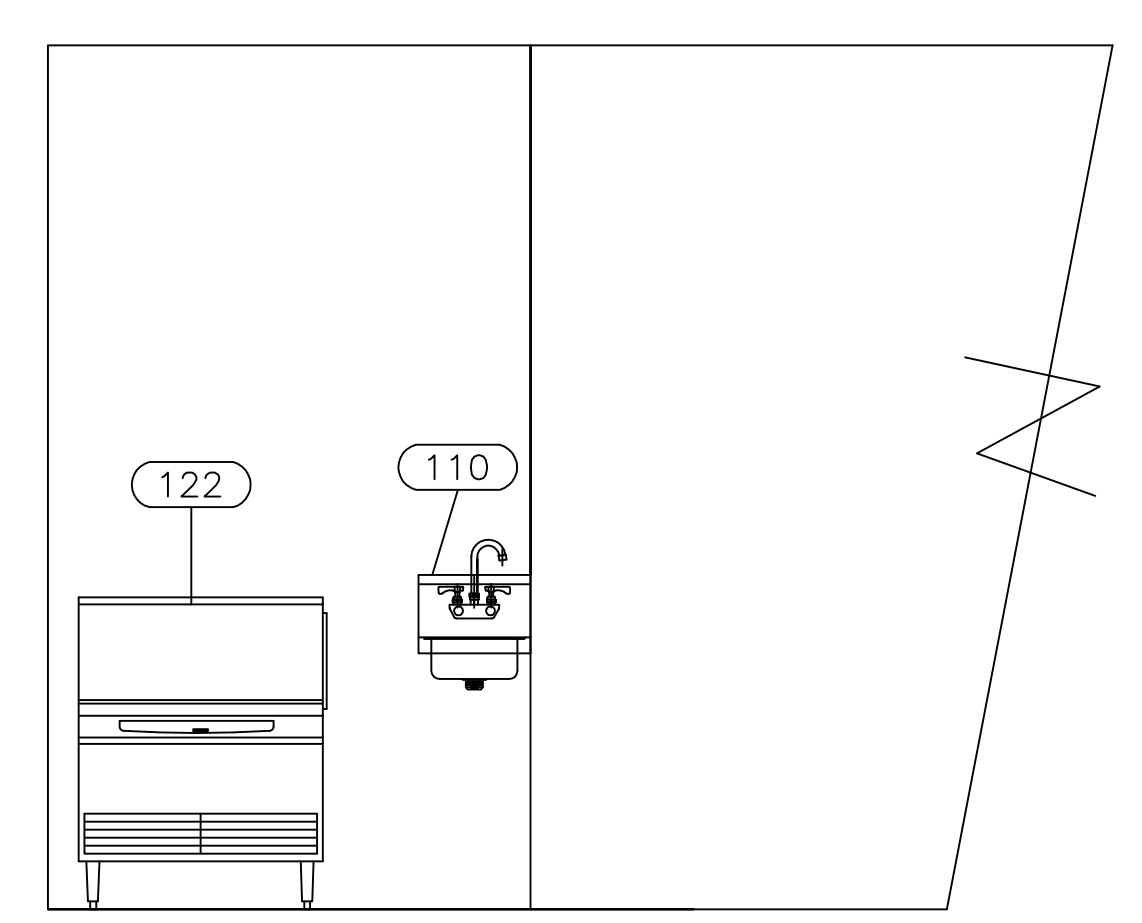

1 ICE MACHINE/ HAND SINK

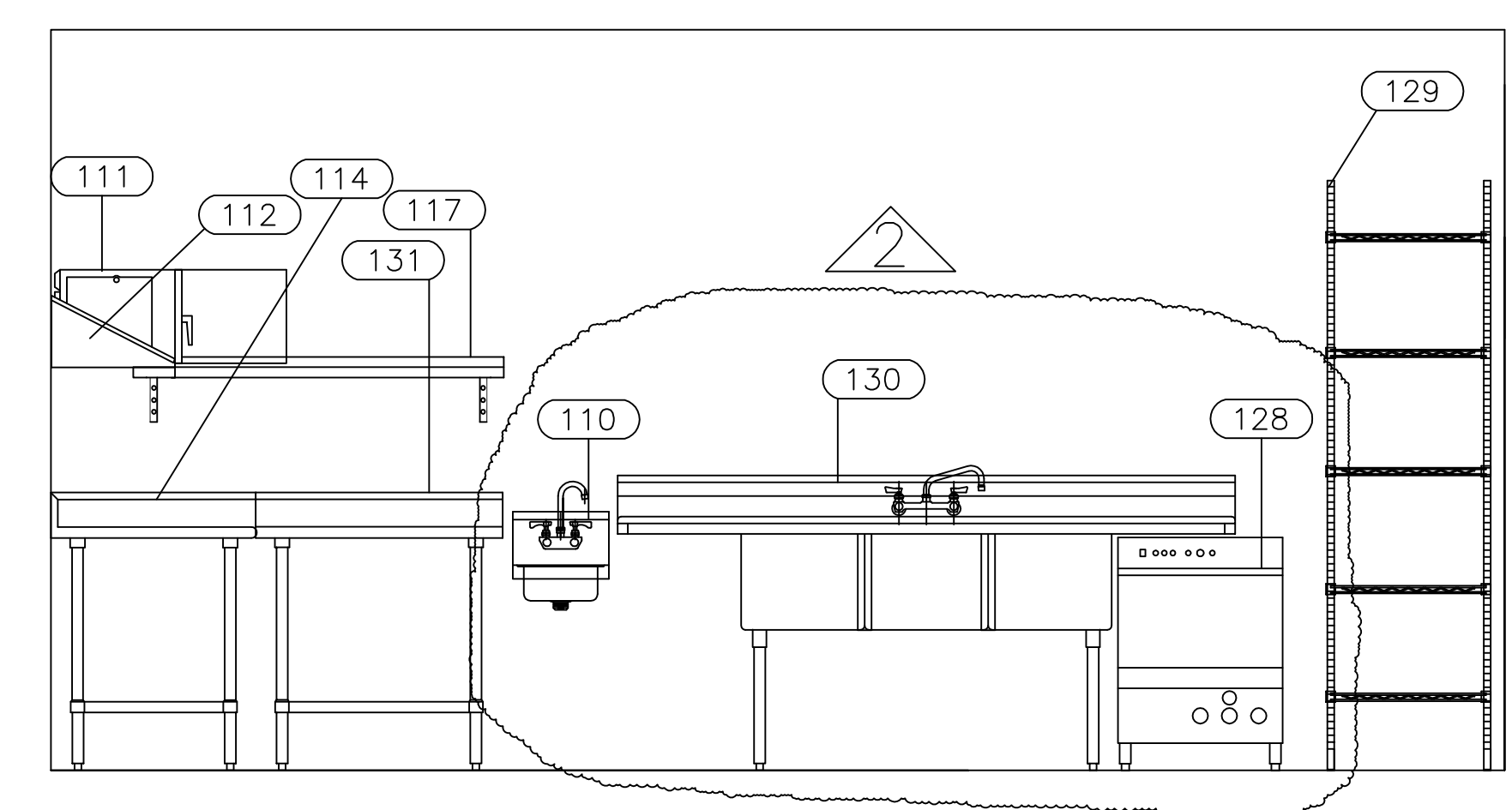

2 3 COMP SINK

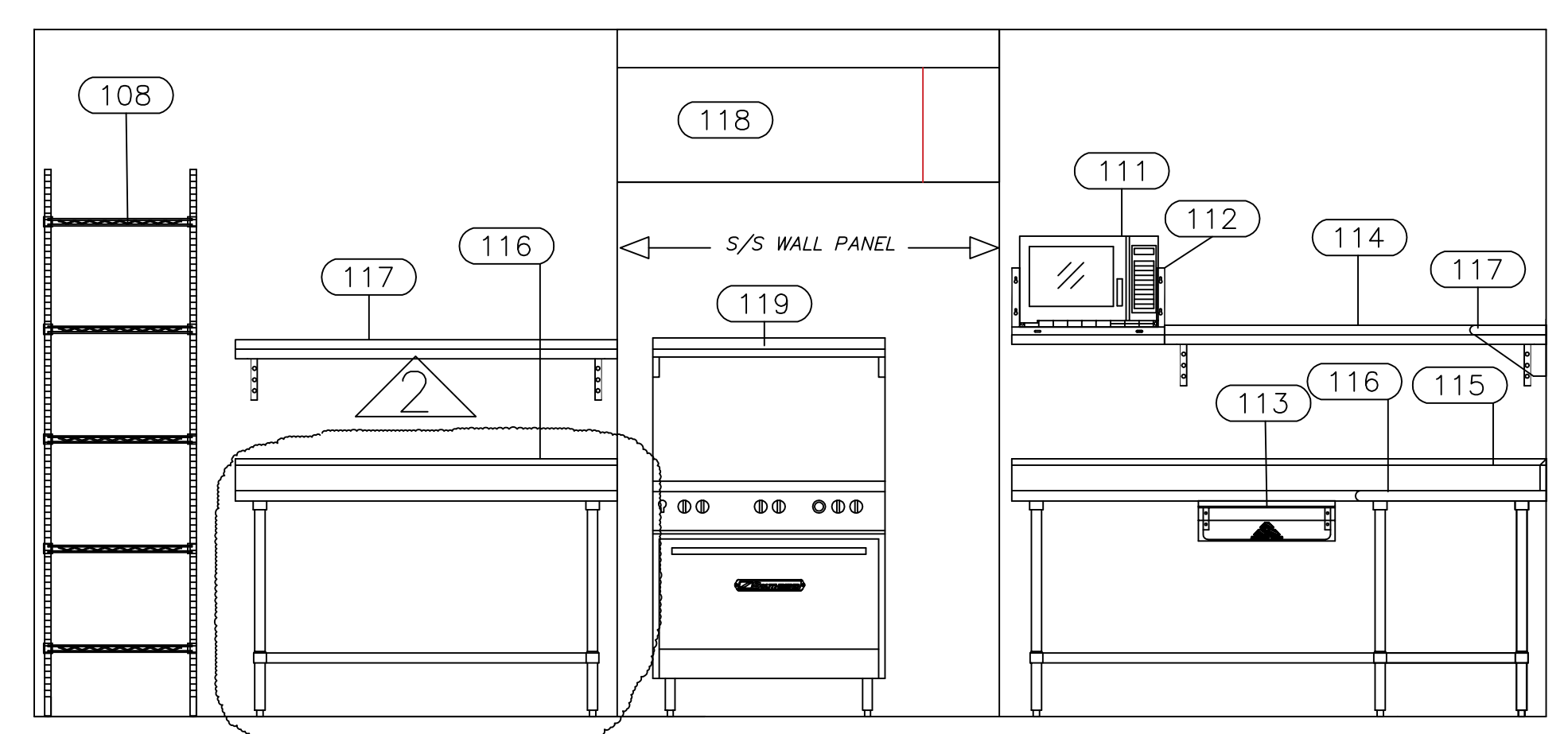

3 6 BURNER

Hangman
CORPORATION
PROFESSIONAL KITCHEN OUTFITTERS
210 Brand Lane • Stafford, TX 77477
281-499-0999 • fax 281-499-0102

DESIGNED BY:	WCM
DRAWN BY:	WCM
CHECKED BY:	HMB
SCALE:	$\frac{1}{2}'' = 1'$
SHEET TITLE:	ELEVATIONS

SHEET NO.
FS-3