

**GENERAL NOTES FOR FOUNDATION SYSTEM**

- CONTRACTOR SHALL REVIEW & BECOME THOROUGHLY FAMILIAR W/ THE CONTENTS OF REFERENCED SOILS REPORT, WHICH WILL BE CONSIDERED AN INTEGRAL PART OF THE CONSTRUCTION DOCUMENTS. ANY PROBLEMS ARISING FROM THE CONTRACTOR'S LACK OF FAMILIARITY WITH SOILS REPORT SHALL BE THE RESPONSIBILITY OF THE CONTRACTOR.
- CONTRACTOR SHALL VERIFY ALL DIMENSIONS & ELEVATIONS W/ ARCHITECTURAL DRAWING BEFORE FABRICATION.

**SUBGRADE PREPARATION AND FILL:**

- STRIP AREAS WITHIN BUILDING LINES TO REMOVE ALL VEGETATION, TOP SOIL AND DEBRIS.
- FOLLOWING STRIPPING, PROOF ROLL EXPOSED SUBGRADE TO IDENTIFY WEAK OR SOFT AREAS. SUCH ZONES SHALL BE REMOVED AND REPLACED WITH SELECT FILL.
- GRADE AREA TO PREVENT PONDING OF WATER. DO NOT ALLOW EXPOSED SUBGRADE TO DRY.
- ALL FILL SHALL BE SELECT MATERIALS FOLLOWS:  
CLEAN SANDY CLAY, FREE OF ORGANIC MATTER  
PLASTICITY INDEX (PI) : 7 TO 20 % LIQUID LIMIT: 28 TO 40 %
- FILL SHALL BE PLACED IN MAXIMUM LOOSE LIFTS OF 8 INCHES AND COMPACTED TO AT LEAST 95% OF STANDARD PROCTOR (ASTM D698 MAXIMUM DRY DENSITY AT OR 2 PERCENTAGE POINTS ABOVE THE OPTIMUM MOISTURE CONTENT).
- PROVIDE 1-8" LOOSE LIFTS OF COMPACTED FILL (TOTAL COMPACTED FILL THICKNESS = 6") AND 2" LEVELING SAND. (NOTE THAT EXISTING GRADE MAY HAVE TO BE CUT TO ACHIEVE THE COMPACTED FILL DEPTH SPECIFIED HEREIN).
- TESTING: ALL COMPACTED FILL SHALL BE TESTED BY A CERTIFIED TESTING AGENCY AT THE RATE OF ONE TEST PER 1,000 SQUARE FEET OF EACH LIFT.

**CONCRETE:**

- ALL CONCRETE WORK SHALL BE IN ACCORDANCE WITH THE "ACI STANDARD BUILDING CODE REQUIREMENT FOR STRUCTURAL CONCRETE: (ACI 318-99)".
- NORMAL WEIGHT CONCRETE (W = 145 PCF) WITH MINIMUM 28 DAY COMPRESSIVE STRENGTH SHALL BE AS BELOW  
PIER FC. = 3000 PSI  
SLAB & BEAM FC. = 4000 PSI
- CONCRETE SHOULD BE PLACED IN THE FOOTING EXCAVATIONS AS SOON AS POSSIBLE BUT NO LATER THAN THREE HOURS AFTER EXCAVATION TO MINIMIZE THE POSSIBILITY OF CAVING OF DRILLED PIERS.
- CLEAN TOPS OF PIERS AND BOTTOM OF GRADE BEAM TRENCHES THOROUGHLY PRIOR TO PLACEMENT OF CONCRETE IN THE GRADE BEAMS.
- SEE ARCHITECTURAL DRAWINGS FOR FLOOR ELEVATIONS, SLOPES AND THE LOCATION OF FLOOR DEPRESSIONS.

**REINFORCING STEEL:**

- BARS - CONFORM TO ASTM A-615-GRADE 60, DOWELS AND STIRRUPS - GRADE 40.
- WELDED WIRE FABRIC - CONFORM TO ASTM A-185 OR A-409, FURNISHED IN FLAT SHEETS AND MUST BE SUPPORTED ON CHAIRS SPACED 4'-0" O.C. MAXIMUM EACH WAY.
- DETAILING - CONFORM TO ACI DETAILING MANUAL, 315-90.  
REINFORCING STEEL COVERAGE:  
FOOTINGS ..... 3" BOTTOM AND SIDES  
GRADE BEAMS ..... 1 1/2" TOP, 3" BOTTOM, 2" SIDES (3" SIDES IF EARTH FORMED)  
SLABS ON GRADE ..... 1 1/4" TOP  
WALLS ..... 1 1/2"
- LAP CONTINUOUS REINFORCING STEEL 36 BAR DIAMETERS.
- SLAB REINFORCEMENT SHALL BE SUPPORTED ON CHAIRS, @ 4'-0" MAXIMUM SQUARE GRID.
- GRADE BEAM BOTTOM REINFORCEMENT SHALL BE SUPPORTED ON CHAIRS @ 6'-0" MAXIMUM SPACING.

**PIPING PENETRATIONS:**

- ALL PIPING PENETRATIONS THROUGH EXTERIOR GRADE BEAMS SHALL BE SLEEVED WITH SCHEDULE 40 PIPE.

**IMPORTANT NOTES ON SITE DRAINAGE:**

- SOILS AT THIS SITE CONTAIN CLAYS, AND VARIATIONS IN MOISTURE CONTENTS WILL PRODUCE VOLUMEN CHANGES IN THE SOILS THAT MAY DETRIMENTAL TO THE SATISFACTORY PERFORMANCE OF THE FOUNDATION SYSTEM.
- SITE DRAINAGE, ESPECIALLY AROUND SLAB EDGES, MUST BE WELL DEVELOPED, SO THAT SURFACE WATER IS POSITIVELY DIRECTED AWAY FROM SLAB EDGES. A MINIMUM OF 5% GRADE SLOPE MUST BE MAINTAINED AT ALL TIMES WITHIN 10 FEET OF ALL SLAB EDGES.
- LOCALIZED PONDING OF WATER, DUE TO PLANTER BEDS, OR OTHER CAUSES, MUST BE PREVENTED DURING OR AFTER COMPLETION OF CONSTRUCTION, OR LANDSCAPING.
- BUILDER SHALL ADVISE OWNER OF THESE SITE DRAINAGE REQUIREMENTS.

**CODE:**

INTERNATIONAL RESIDENTIAL CODE (IRC 2006)

**DESIGN LOADS:**

1. ROOF LIVE LOADS	16 PSF		
2. FLOOR LIVE LOADS	(INTL RESIDENTIAL CODE-2003, TABLE R301.5)		
EXTERIOR BALCONIES	60 PSF	SLEEPING ROOMS	30 PSF
DECKS	40 PSF	OTHER ROOMS	40 PSF
FIRE ESCAPES	40 PSF	ATTIC W/ STORAGE	20 PSF
STAIRS	40 PSF	ATTIC W/O STORAGE	10 PSF
GUARDRAILS & HANDRAILS	200 PSF *	GARAGE	50 PSF

\* A SINGLE CONCENTRATED LOAD APPLIED IN ANY DIRECTION @ ANY POINT ALONG THE TOP.

**WIND LOADS**

BASIC WIND DESIGN VELOCITY	110 MPH (3-SECOND GUST WIND SPEED)
EXPOSURE: B	IMPORTANCE FACTOR: 1

**GENERAL NOTES: COORDINATION W/ ARCH. DWGS.**

- CONTRACTOR SHALL REVIEW ARCHITECTURAL AND STRUCTURAL DRAWINGS JOINTLY PRIOR TO CONSTRUCTION, TO ENSURE COORDINATION OF ALL PHASES OF CONSTRUCTION DESCRIBED IN THESE DRAWINGS. DISCREPANCIES SHALL BE BROUGHT TO THE ATTENTION OF BOTH ARCHITECT AND ENGINEER, PRIOR TO PROCEEDING WITH CONSTRUCTION WORK.
- THE FOLLOWING ITEMS, IN PARTICULAR, HAVE TO BE CLOSELY COORDINATED BETWEEN ARCHITECTURAL AND STRUCTURAL DRAWINGS:
  - ALL DIMENSIONS;
  - SLAB AND FLOOR ELEVATIONS, SLOPES, AND LOCATION AND DIMENSIONS OF ANY RECESSES, INCLUDING THOSE INTENDED FOR SHOWERS, ELEVATORS, FLOORING MATERIALS, ETC.
  - CURBS AND VENEER LEDGES;
  - CEILING HEIGHTS AND CEILING CONDITIONS;
  - ROOF GEOMETRY AND SLOPES.

**SOILS REPORT:**

- REFERENCE:**  
REPORT NO: EE-1227309-G  
DATE: OCTOBER 2, 2012  
PREPARED BY: EARTH ENG-INC.
- SOIL DATA:**  
PLASTICITY INDEX (PI) OF SURFICIAL SOILS: 43-67  
LIQUID LIMIT: 52-92 POTENTIAL VERTICAL RISE (PVR) : VERY HIGH
- ALLOWABLE DESIGN BEARING PRESSURES:**  
DEAD & SUSTAINED LIVE LOADS: 2,500 PSF TOTAL LOADS: 3,750 PSF
- DESCRIPTION OF BEARING SURFACE: VERY STIFF REDDISH BROWN CLAY
- CONTRACTOR MUST REVIEW SOIL REPORT FOR SITE PREPARATION, EXISTING CONDITION, SELECT FILL AND DRILLED SHAFT INSTALLATION. IN CASE OF SAND ENCOUNTER AT THE SITE THEN CASTING MUST BE USED WITHOUT ADDITION COST TO THE OWNER.

**NOTES ON PRESSURE-TREATED LUMBER:**

- ALL WOOD MEMBERS IN CONTACT WITH CONCRETE, OR EXPOSED TO WEATHER OR MOISTURE (SUCH AS PORCH & BALCONY FRAMING) SHALL BE PRESSURE-TREATED.
- CURRENTLY, THE PRODUCT COMMONLY USED FOR PRESSURE TREATMENT IS ALKALINE COPPER QUATERNARY (ACQ). THIS MATERIAL IS EXTREMELY CORROSIVE. ONLY HOT-DIPPED GALVANIZED ANCHOR BOLTS, THRU BOLTS, NAILS, OR OTHER CORROSIVE-RESISTANT FASTENERS, SHALL BE USED WITH ACQ-TREATED LUMBER. FASTENER MANUFACTURER OR SUPPLIER SHALL BE CONSULTED ON THE SUITABILITY OF GALVANIZED FASTENER FOR USE WITH TREATED LUMBER.

THE CONTRACTOR MUST HAVE A MINIMUM OF 10 YEARS EXPERIENCE IN RESIDENTIAL CONSTRUCTION

**NOTES:**

IT IS STRONGLY RECOMMENDED THAT INSPECTION IS REQD PRIOR TO CONC. POUR TO AVOID MISPLACEMENT OF REINFORCEMENT

**NOTES:**

- ALL FOOTING ARE AS SHOWN ON PLAN.
- ALL COLUMN ARE AS SHOWN ON CEILING PLAN.
- C.J. ON PLAN INDICATES CONTROL JOINT & K.W INTACATEX KEY AWAY
- REPLACE EXISTING SOIL WITHING BUILDING AS RECOMMENDED BY GEOTECHNICAL REPORT NO. EE-1227309-G BY ASSOCIATED EARTH ENGINEERING, INC. HOUSTON, TEXAS.
- ALL ANCHOR BOLTS MUST BE IN PLACE BEFORE POURING CONCRETE.
- SITE SHOULD BE GRADED TO SHED ALL RAIN WATER AWAY FROM STRUCTURE. NO WATER POND ALLOWED AROUND BUILDING.
- WATER & SAND MAY ENCOUNTER, IT IS CONTRACTORS RESPONSIBILITY USE PUMP TO DE WATERING SYSTEM & STRAIGHT DRILLED SHAFT IF REQUIRED DUE TO SAND. (REFER TO SOIL REPORT).
- USE 6" VOID BOXES UNDER CONC. SLAB

REFER TO DRAWING SIC FOR REINFORCEMENT DETAILS

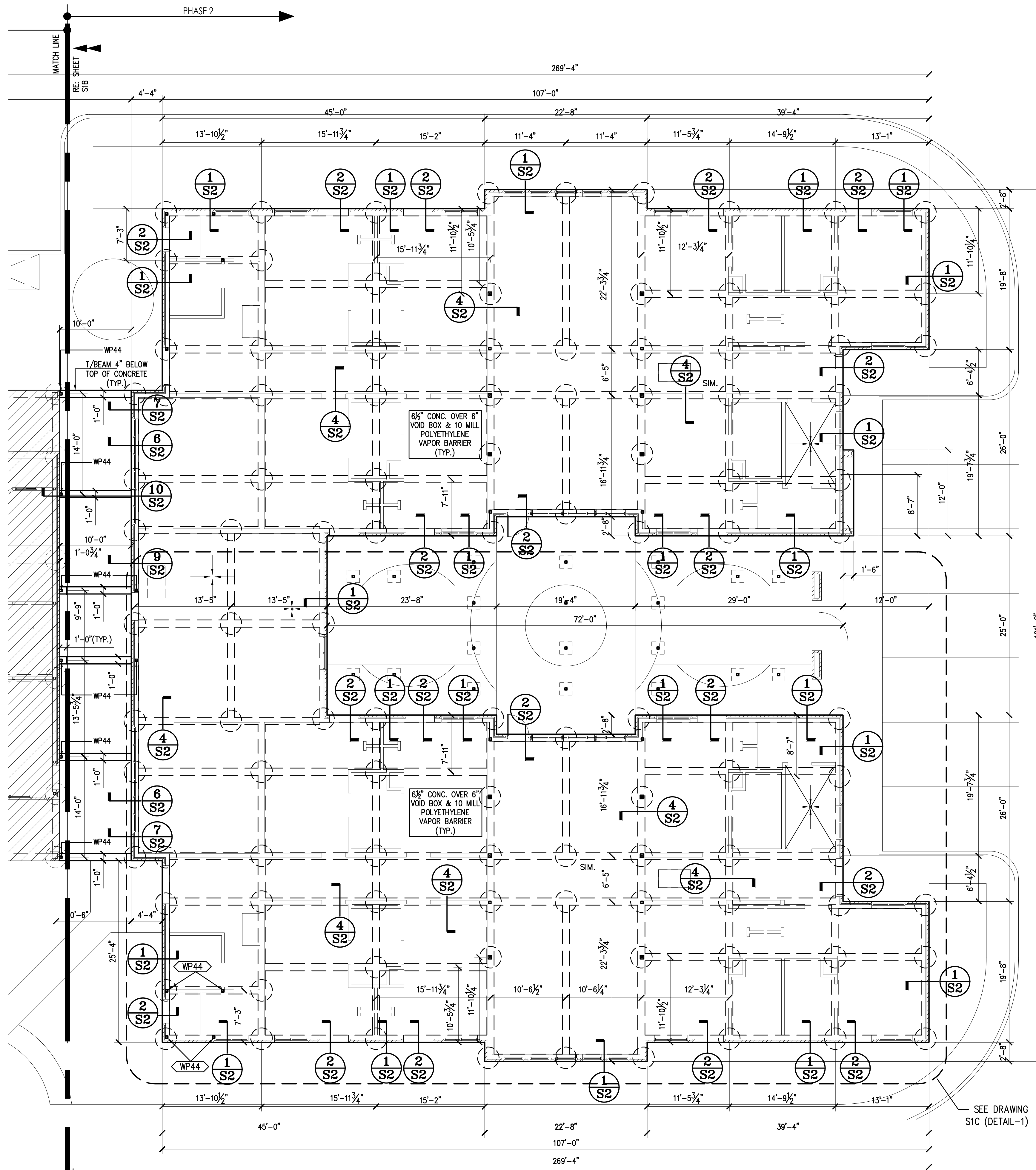

**FOUNDATION PLAN**  
SCALE: 1/8" = 1'-0"

REFER TO DRAWING SIC FOR REINFORCEMENT DETAILS

CONTRACTOR TO VERIFY ALL DIMENSIONS, ELEVATIONS, SLOPES, RECESS, AND COORDINATE DETAILS WITH ARCHITECTURAL DRAWINGS. ALL DIMENSIONS & ELEVATION ON ARCHITECTURAL DRAWINGS SHALL GOVERN. IT IS CONTRACTOR'S RESPONSIBILITY TO REPORT TO ENGINEER ABOUT DISCREPANCY IN DRAWINGS PRIOR TO FABRICATION & BIDDING.

**FOUNDATION PLAN**

**OPTIMUM PERSONAL CARE PH.2**

1110 LAKEVIEW DRIVE  
SUGAR LAND, TX. 77478

**ISSUE HISTORY**

DATE	ISSUED FOR
	CLIENT REVIEW
	PERMIT
	CONSTRUCTION

09/10/15

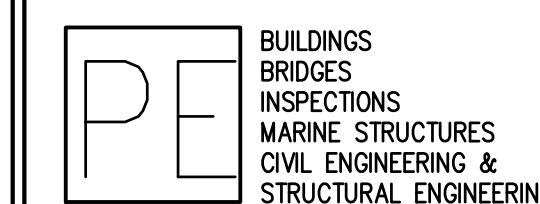

**PARAMOUNT ENGINEERING LLC**

10145 LONG POINT DR.  
HOUSTON, TX 77043

TEL : (713) 636-9977  
FAX : (713) 888-9872  
CEL : (713) 204-1742

TBPE REGISTRATION # F-3394

DRAWN BY: Z.A. CHECKED BY: M.M.

PROJ. NO.: PE12-225

SHEET: **S1A**

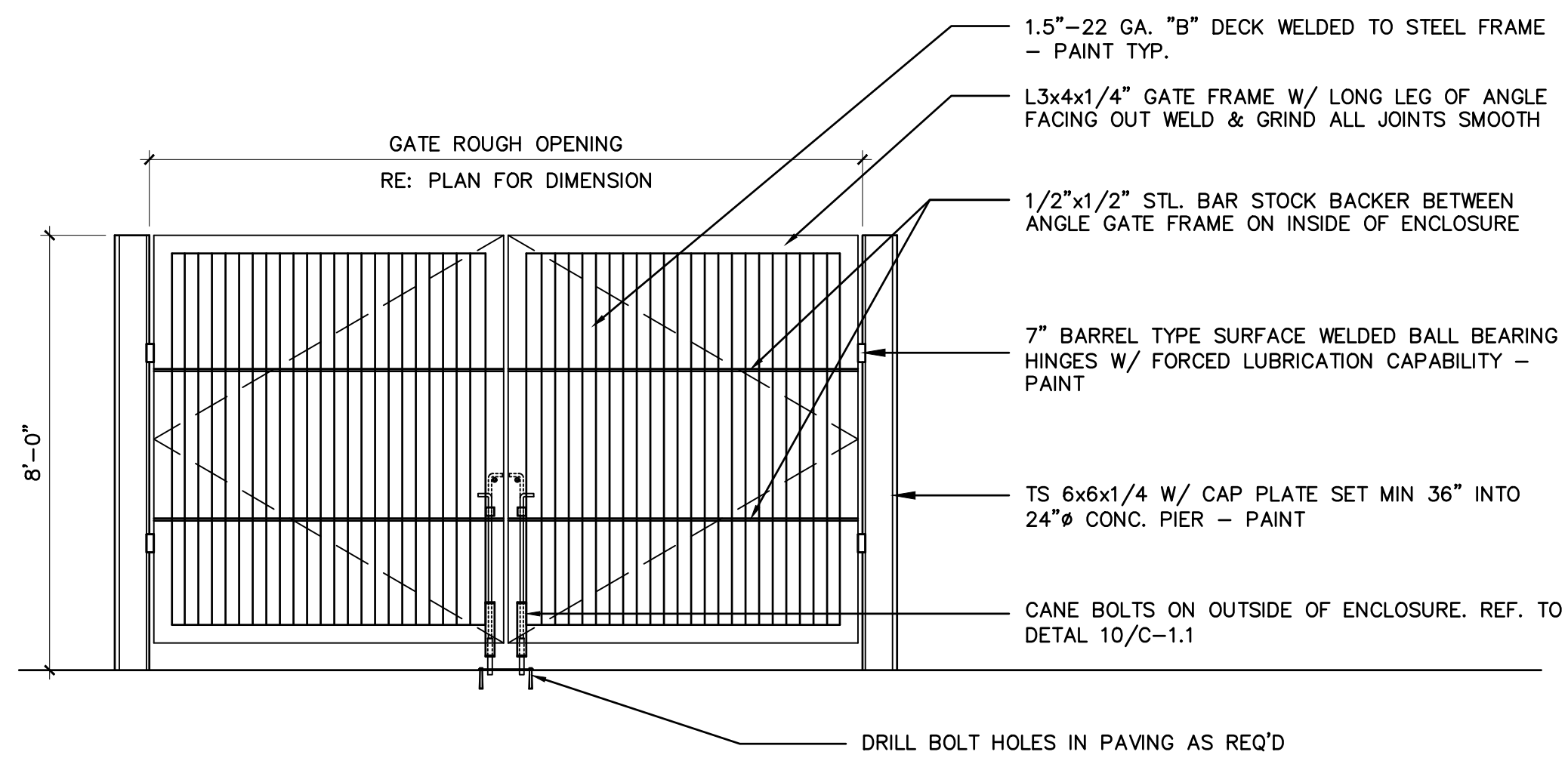

**1 TRASH ENCLOSURE GATE ELEV.**  
SCALE: 3/8" = 1'-0"

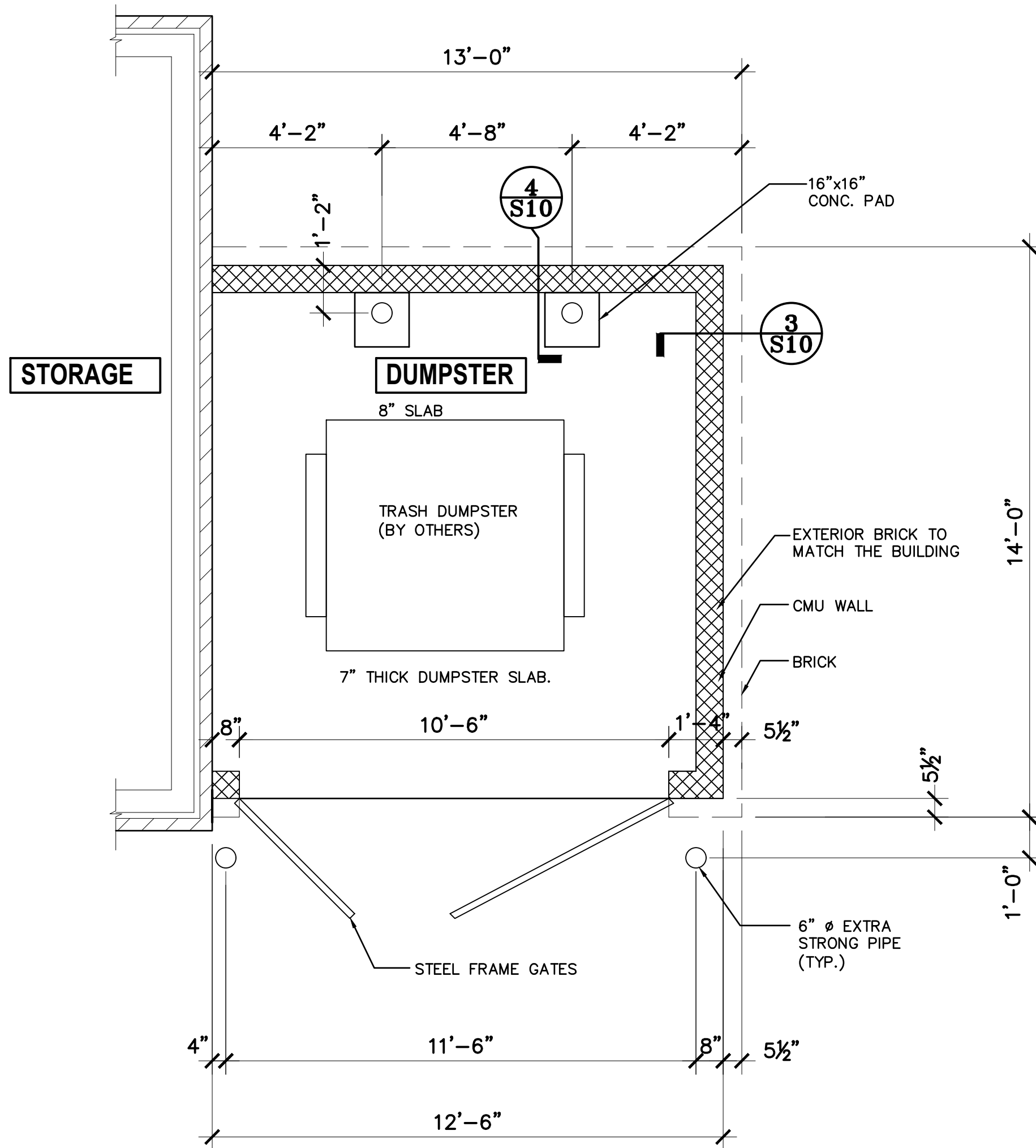

**2 TRASH ENCLOSURE PLAN**  
SCALE: 3/8" = 1'-0"

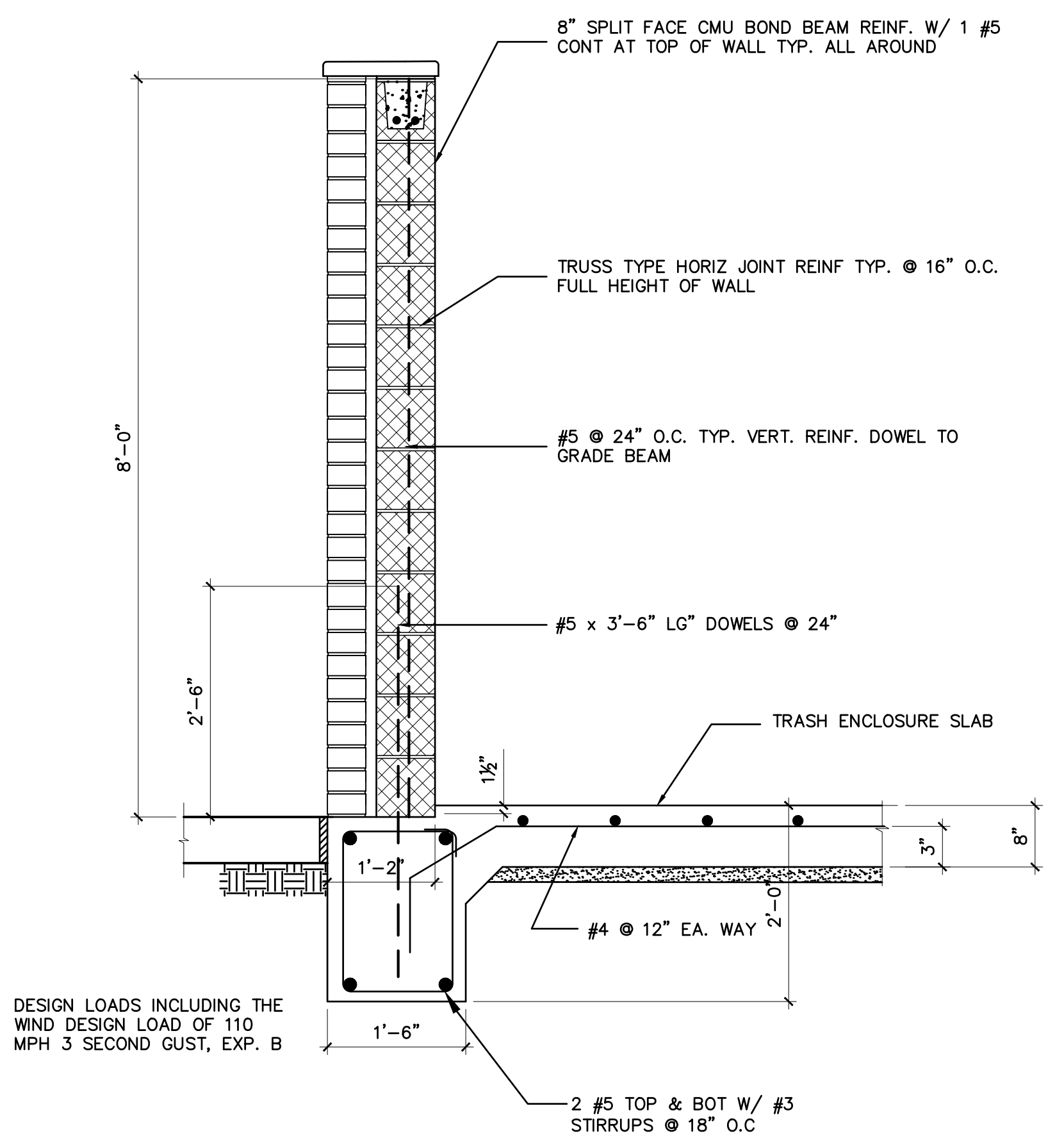

**3 TRASH ENCLOSURE WALL/ FOUNDATION**  
SCALE: 3/4" = 1'-0"

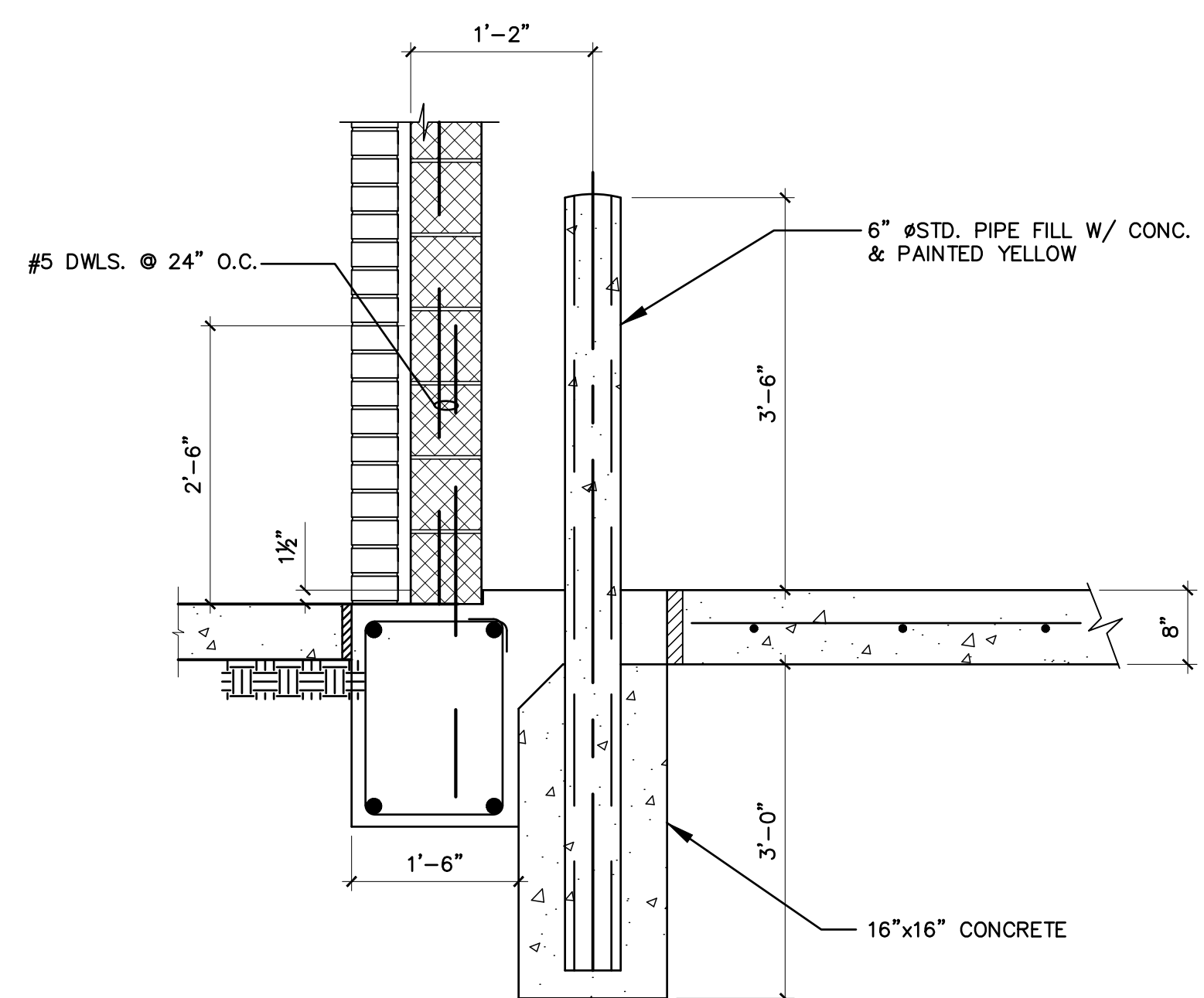

**5 SECTION: TYP. BOLLARD DETAIL**  
SCALE: 3/4" = 1'-0"

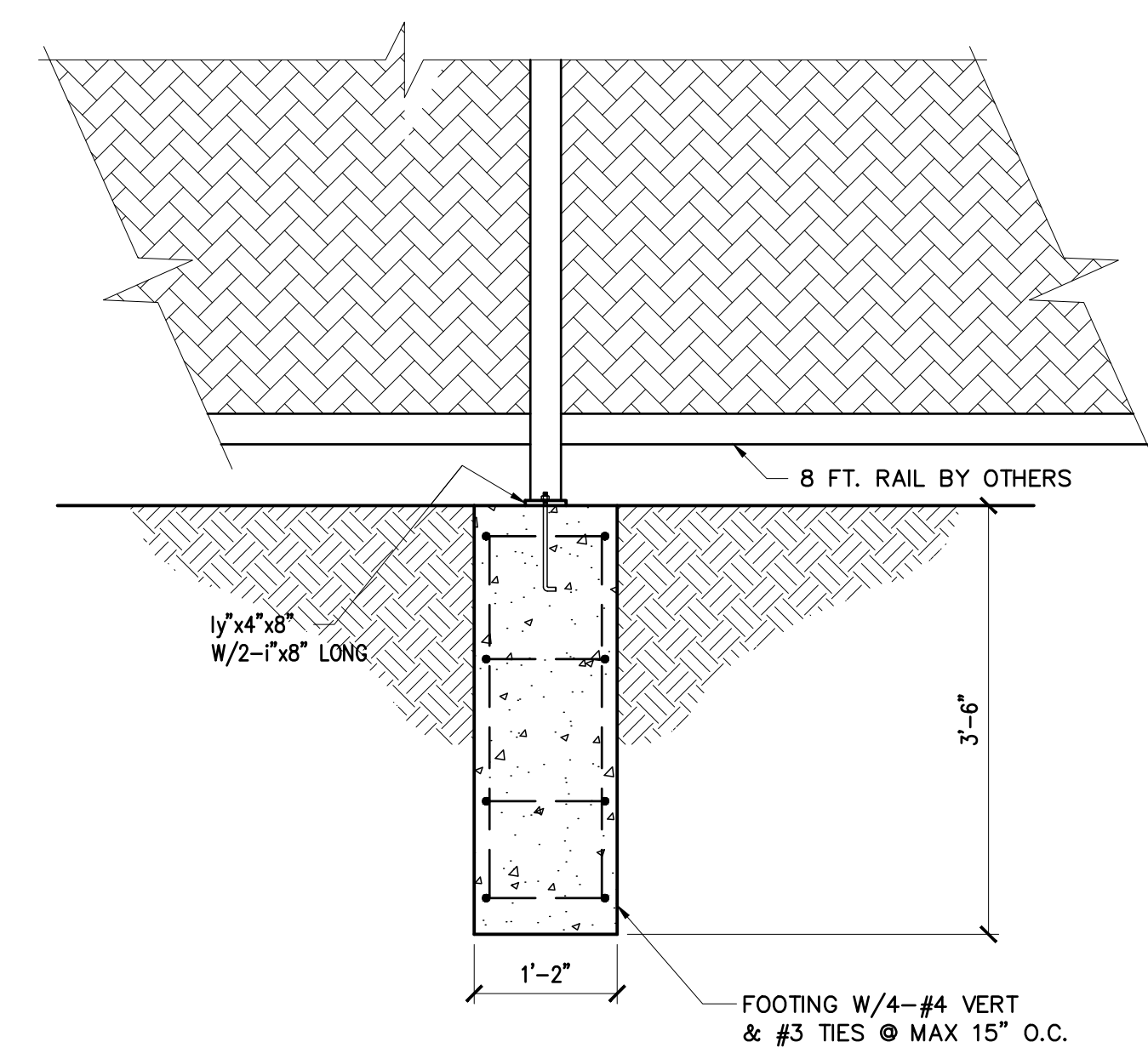

**6 SECTION: FENCE POST FOUNDATION**  
SCALE: 3/4" = 1'-0"

**4 SECTION:**  
SCALE: 3/4" = 1'-0"

**GARAGE & DUMPSTER FOUNDATION**

**OPTIMUM PERSONAL CARE PH.2**  
1110 LAKEVIEW DRIVE  
SUGAR LAND, TX. 77478

ISSUE HISTORY	
DATE	ISSUED FOR
	CLIENT REVIEW
	PERMIT
	CONSTRUCTION

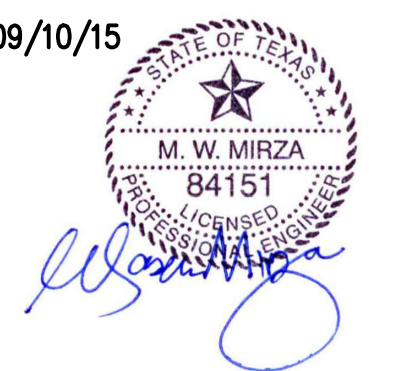

**PE** BUILDINGS  
BRIDGES  
INSPECTIONS  
MARINE STRUCTURES  
CIVIL ENGINEERING &  
STRUCTURAL ENGINEERING

**PARAMOUNT ENGINEERING LLC**

10145 LONG POINT DR.  
HOUSTON, TX 77043  
TEL : (713) 636-9977  
FAX : (713) 888-9872  
CEL : (713) 204-1742

TBPE REGISTRATION # F-3394

DRAWN BY: E.V. CHECKED BY: M.M.

PROJ. NO.: PE12-225

SHEET: **S10**

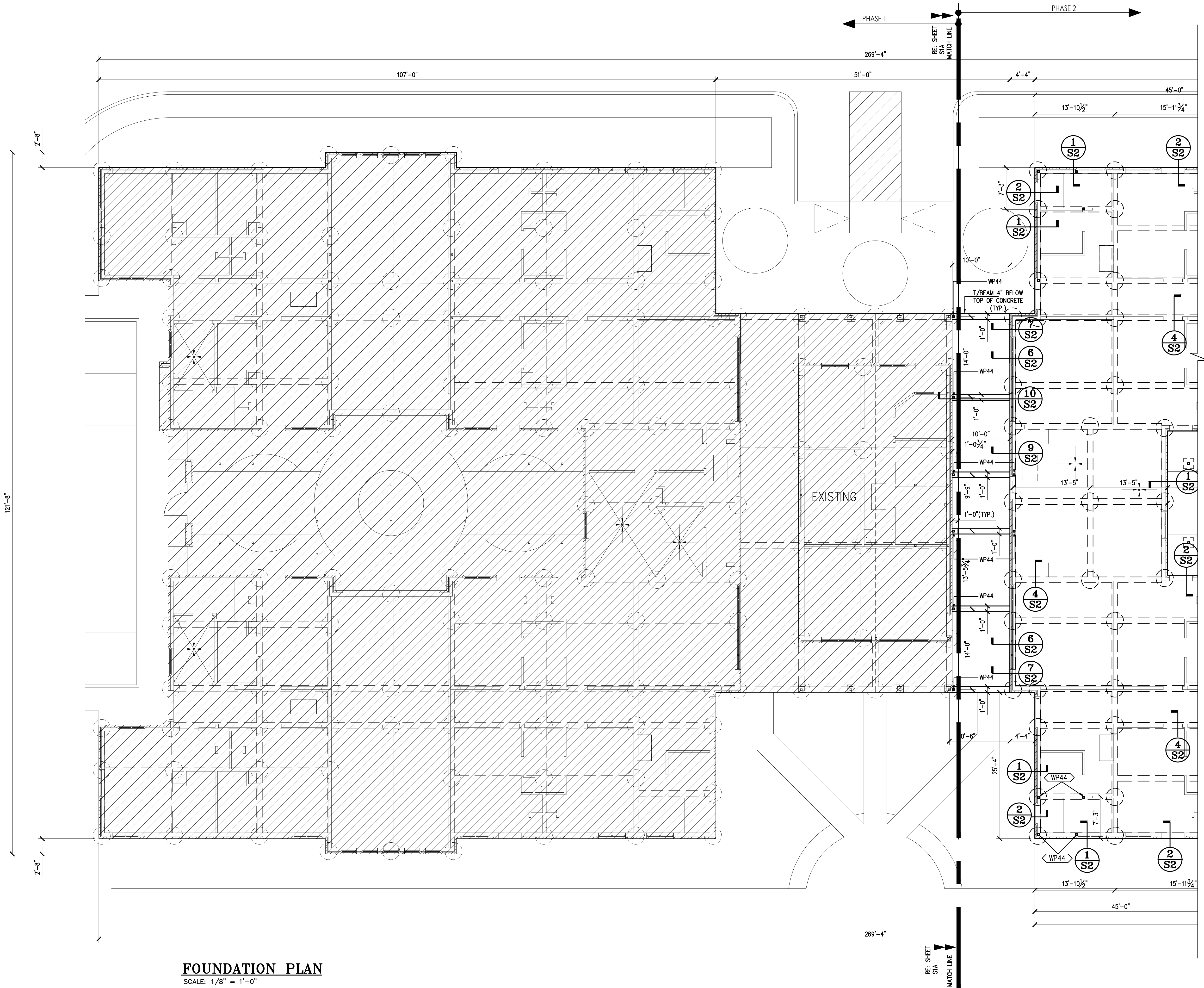

**FOUNDATION PLAN**  
SCALE: 1/8" = 1'-0"

**FOUNDATION PLAN**

**OPTIMUM PERSONAL CARE PH.2**

1110 LAKEVIEW DRIVE  
SUGAR LAND, TX. 77478

**ISSUE HISTORY**

DATE	ISSUED FOR
	CLIENT REVIEW
	PERMIT
	CONSTRUCTION

09/10/15

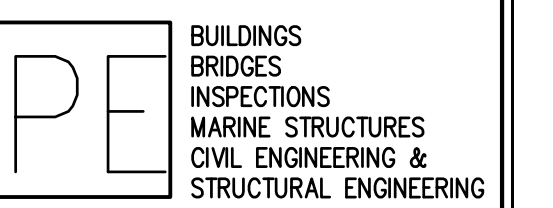

BUILDINGS  
BRIDGES  
INSPECTIONS  
MARINE STRUCTURES  
CIVIL ENGINEERING &  
STRUCTURAL ENGINEERING

**PARAMOUNT ENGINEERING LLC**

10145 LONG POINT DR.  
HOUSTON, TX 77043  
TEL : (713) 636-9977  
FAX : (713) 888-9872  
CEL : (713) 204-1742

TBPE REGISTRATION # F-3394

DRAWN BY: E.V. H.P. CHECKED BY: M.M.

PROJ. NO.: PE12-225

SHEET: **S1B**

**PARTIAL  
FOUNDATION  
PLANS**

**OPTIMUM PERSONAL CARE PH.2**  
1110 LAKEVIEW DRIVE  
SUGAR LAND, TX. 77478

**ISSUE HISTORY**

DATE	ISSUED FOR
	CLIENT REVIEW
	PERMIT
	CONSTRUCTION

09/10/15

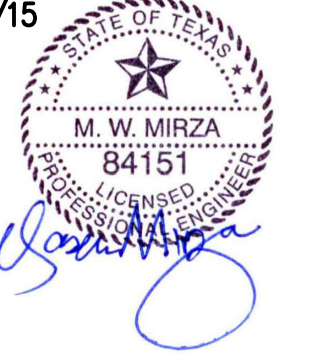

**PE** BUILDINGS  
BRIDGES  
INSPECTIONS  
MARINE STRUCTURES  
CIVIL ENGINEERING &  
STRUCTURAL ENGINEERING

**PARAMOUNT  
ENGINEERING  
LLC**

10145 LONG POINT DR.  
HOUSTON, TX 77043  
TEL : (713) 636-9977  
FAX : (713) 888-9872  
CEL : (713) 204-1742

TBPE REGISTRATION # F-3394

DRAWN BY: Z.A. CHECKED BY: M.M.

PROJ. NO.: PE12-225

SHEET: **S1C**

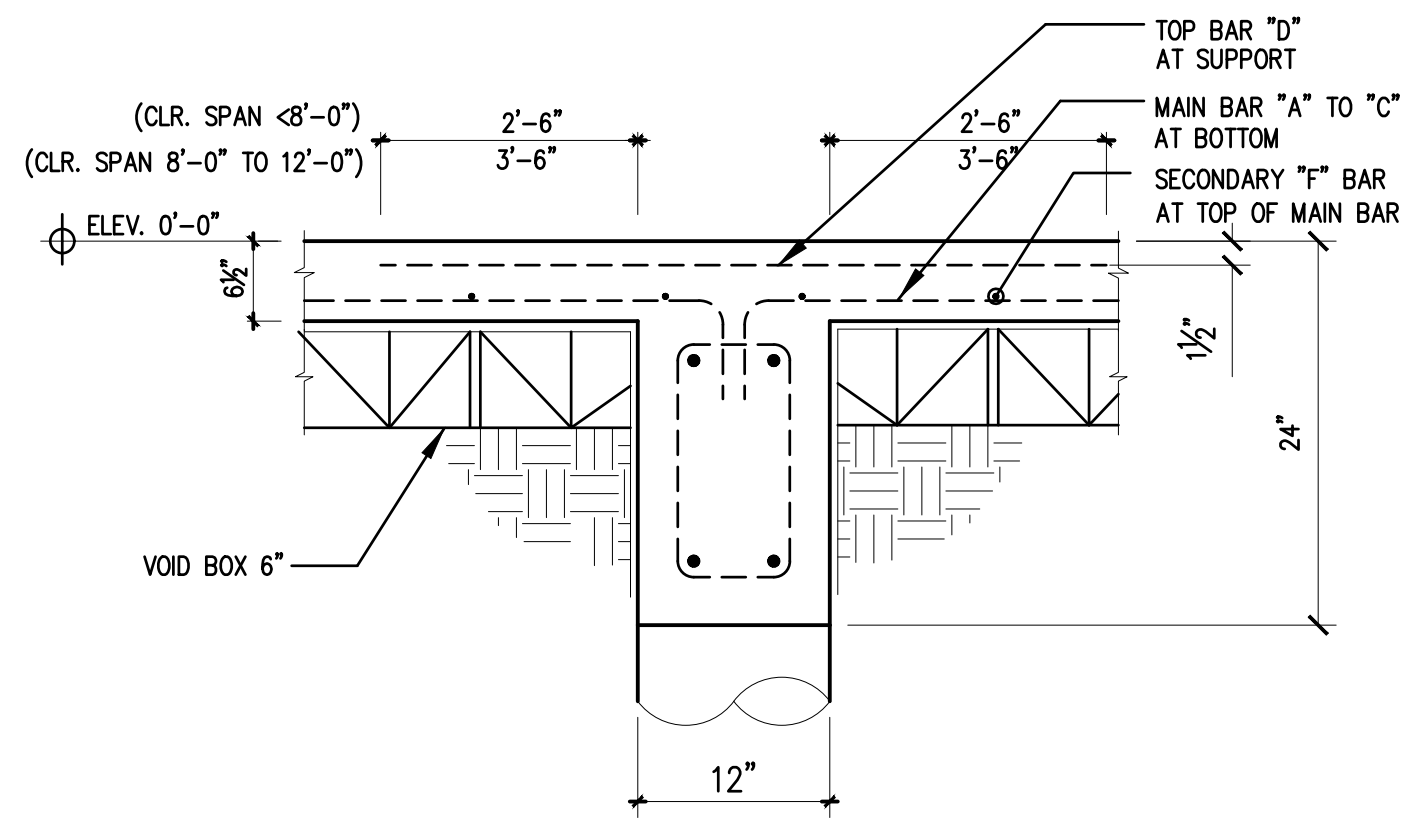

**DETAIL-A**  
SLAB REINFORCEMENT AT  
INTERIOR SUPPORT BEAM  
NOT TO SCALE

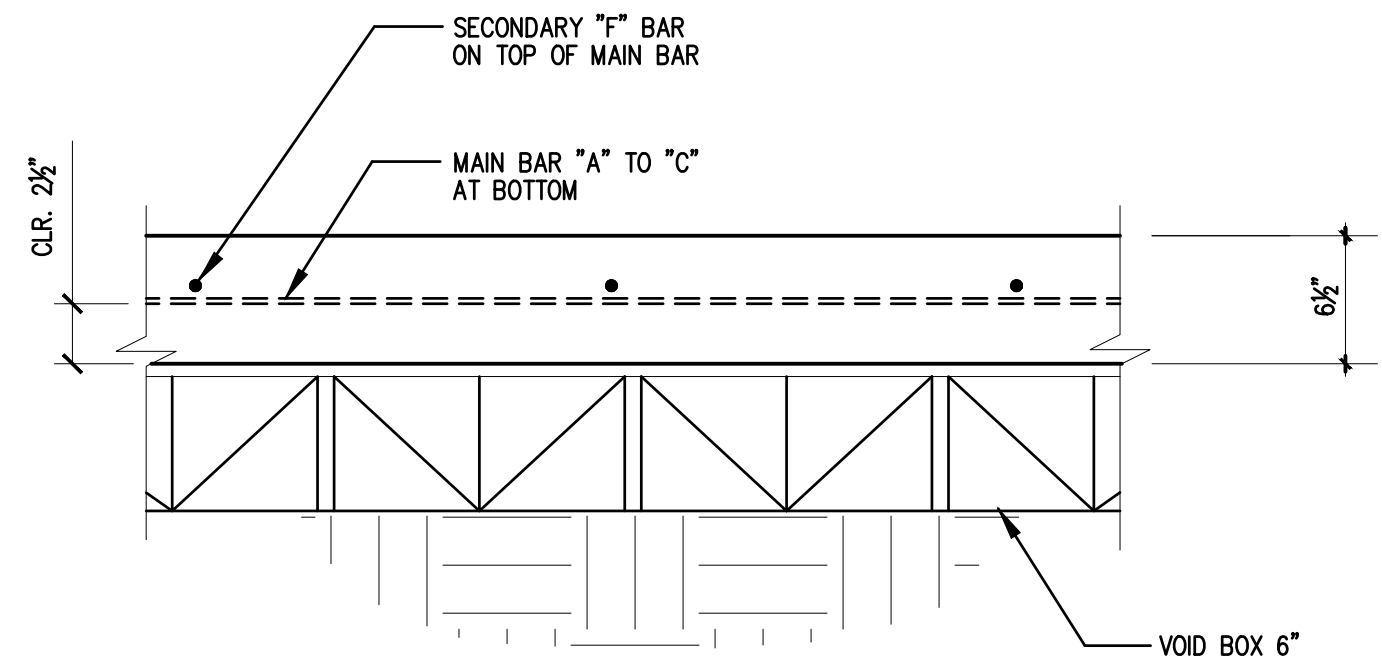

**SECTION: TYPICAL SLAB  
REINFORCEMENT ARRANGEMENT**  
NOT TO SCALE

**SCHEDULE OF REINFORCEMENT  
OF STRUCTURAL SLAB**

BAR I.D.	LOCATION	SIZE & SPACING
A	MAIN BAR AT BOTTOM	#5 @ 12"
B	MAIN BAR AT BOTTOM	#5 @ 9"
C	MAIN BAR AT BOTTOM	#5 @ 8"
D	TOP BAR AT SUPPORT. SEE DETAIL A ON THIS SHEET	#5 @ 12"
E	3'-6" LONG BAR TOP AT SUPPORT	#5 @ 12"
F	SECONDARY BAR AT BOTTOM	#3 @ 15"

**LEGEND:**  
→ DIRECTION OF REINFORCEMENT EXTEND  
SUPPORT TO SUPPORT

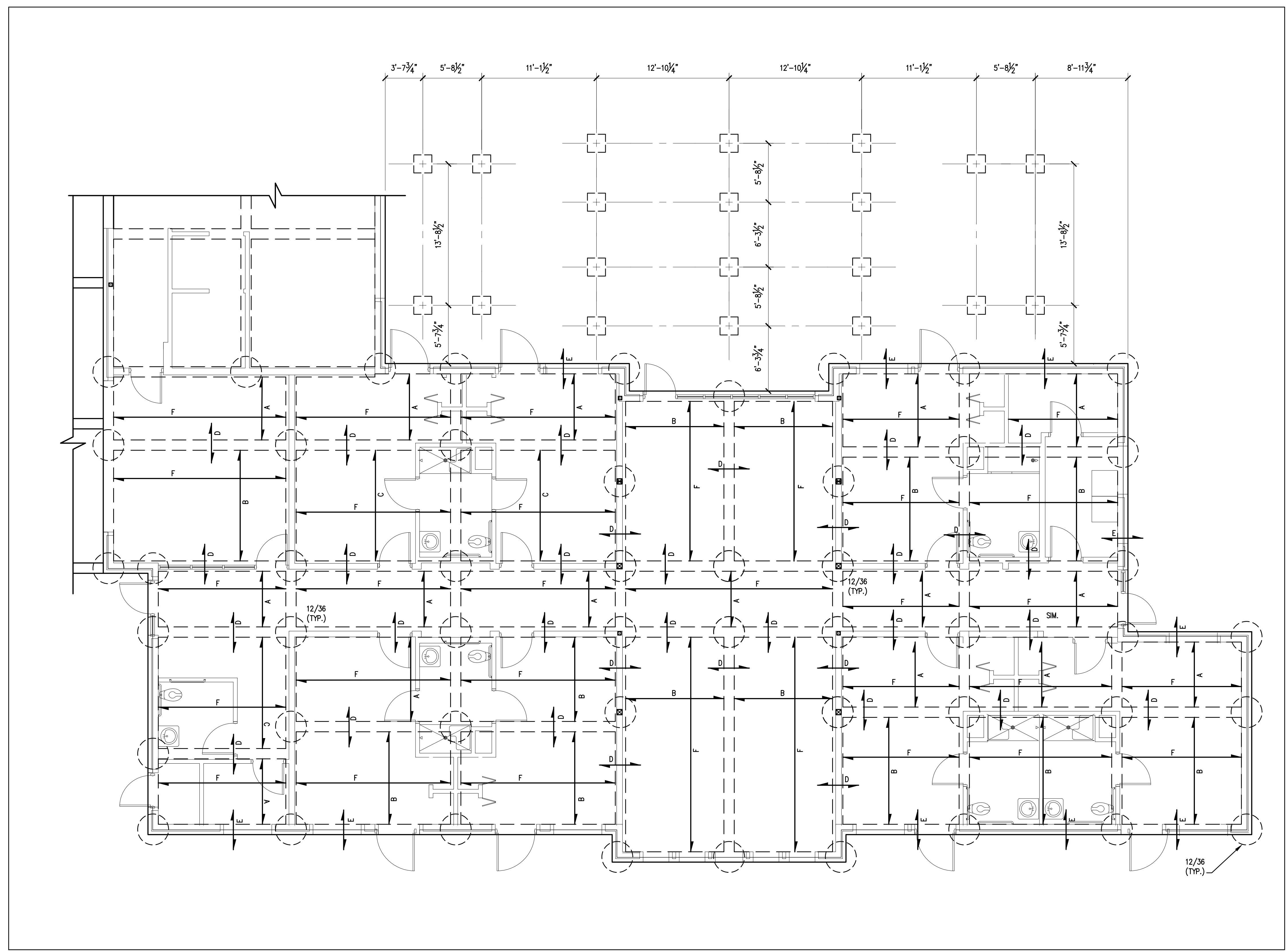

**DETAIL-1: TYPICAL SLAB REINFORCEMENT**  
SCALE: 3/16" = 1'-0"

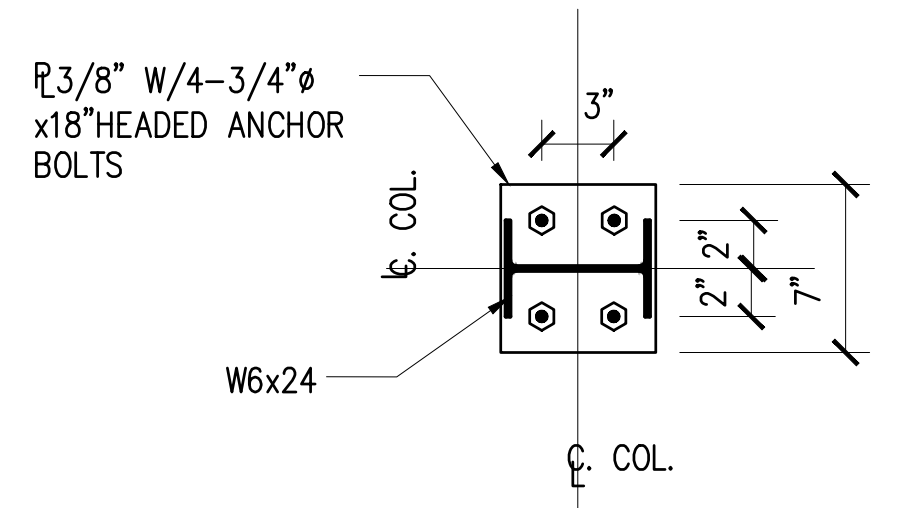

**BASE PLATE DETAIL**

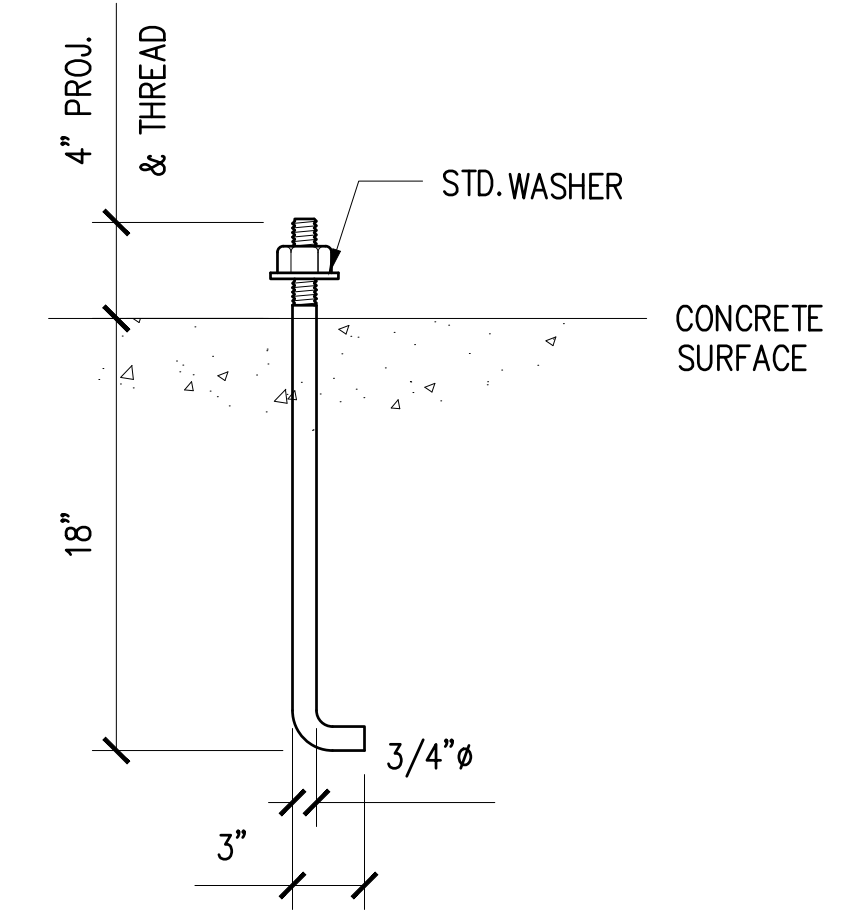

**ANCHOR BOLT DETAIL**

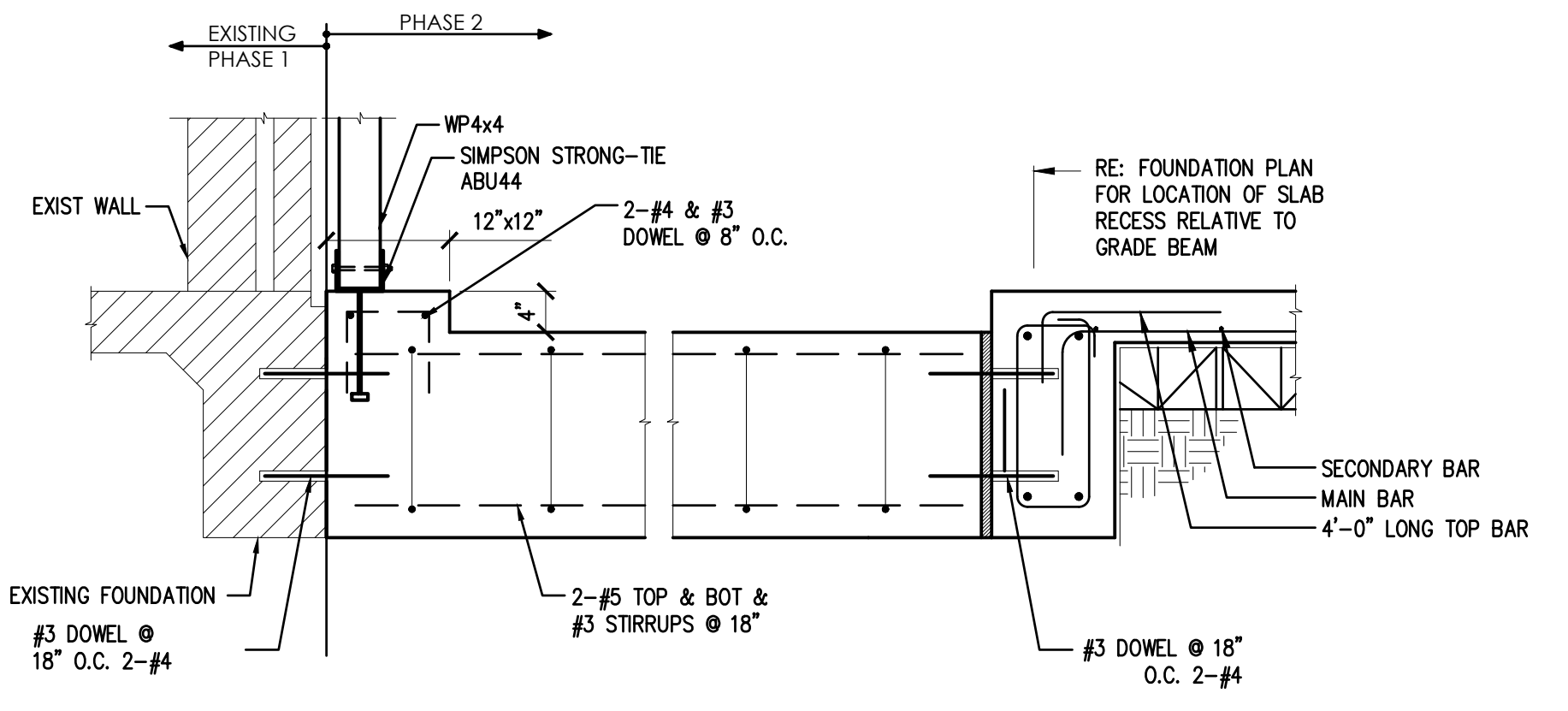

**10 SECTION: CONN. BETWEEN WALK WAY & EXISTING GRADE BEAMS**

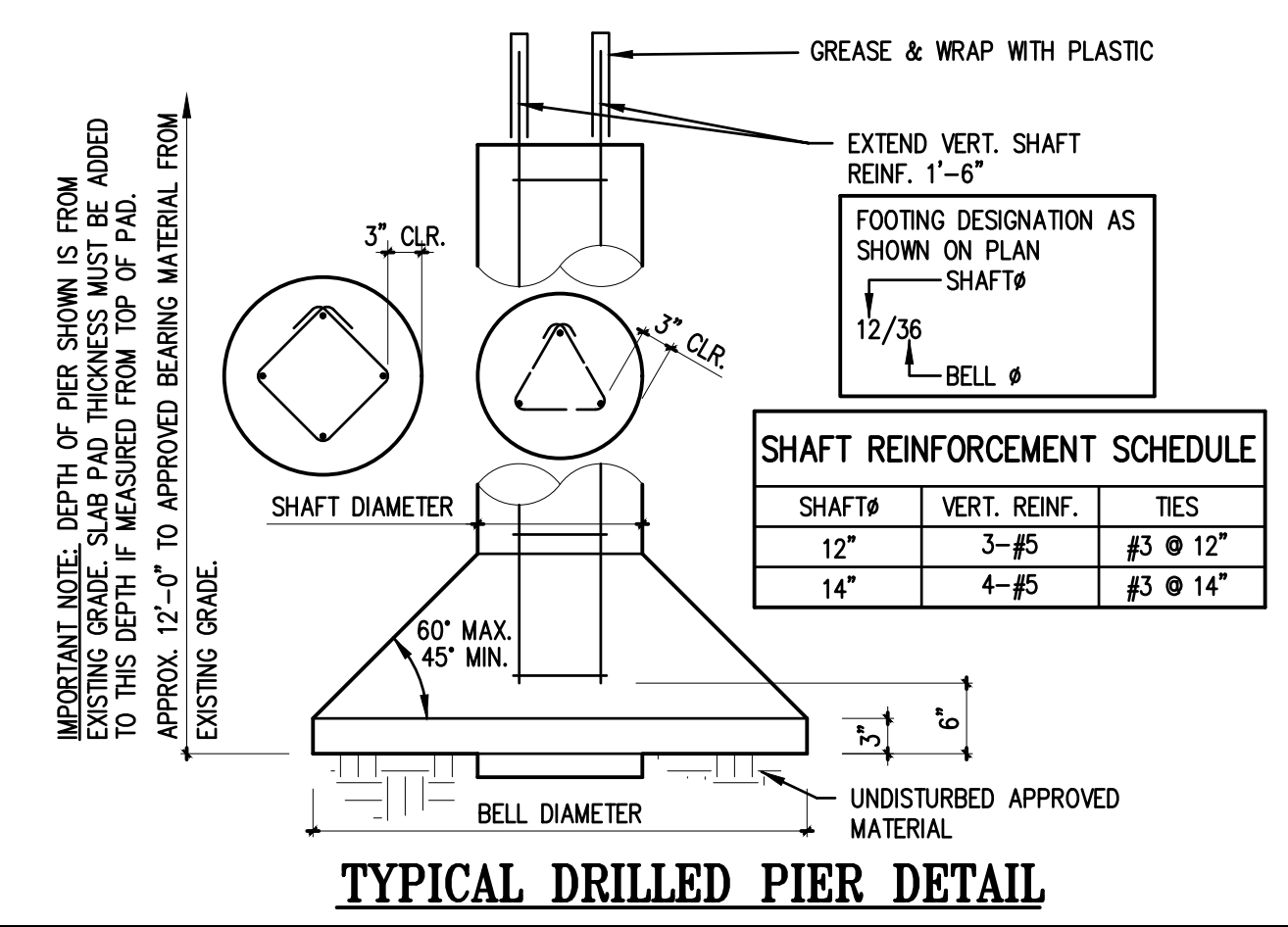

**TYPICAL DRILLED PIER DETAIL**

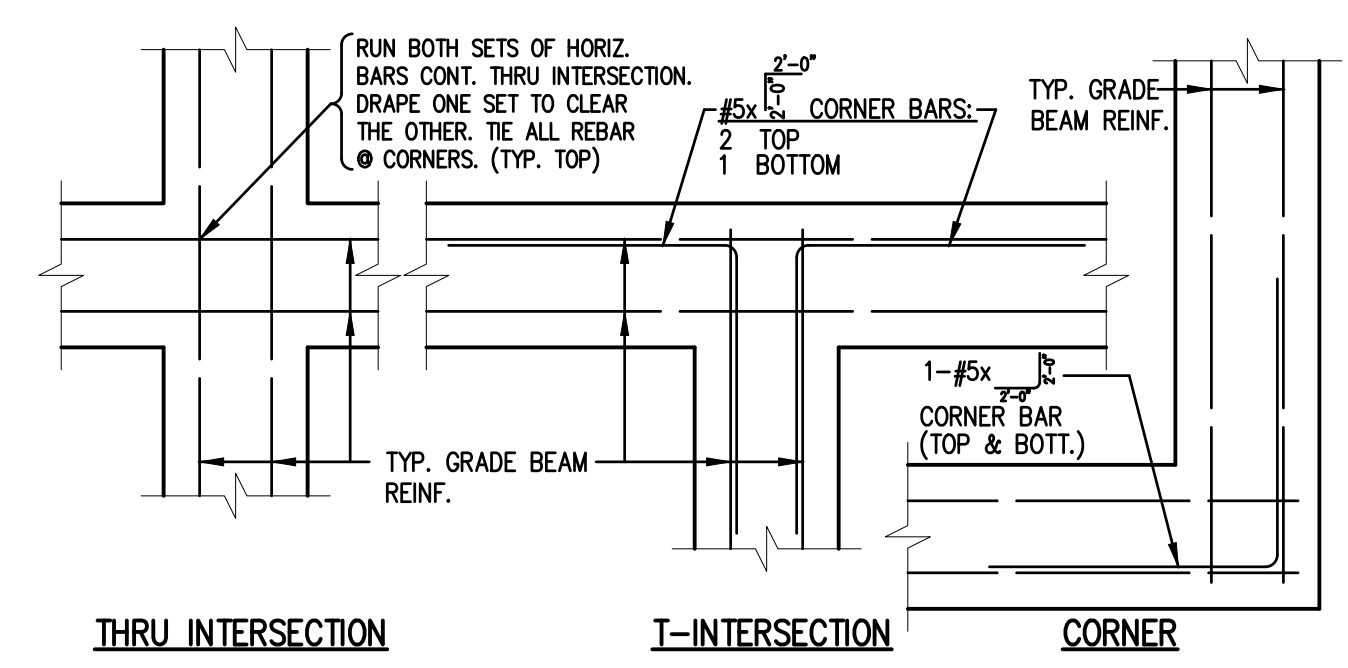

**TYPICAL REINFORCEMENT DETAILS @ GRADE BEAM INTERSECTIONS**

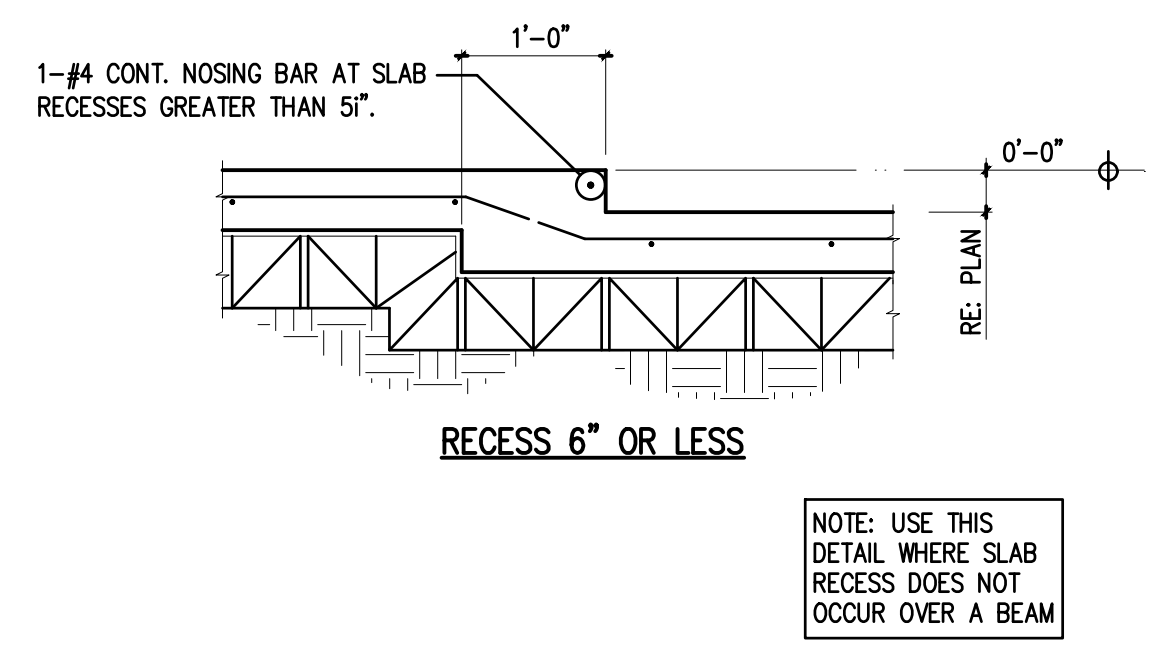

**RECESS 6" OR LESS**

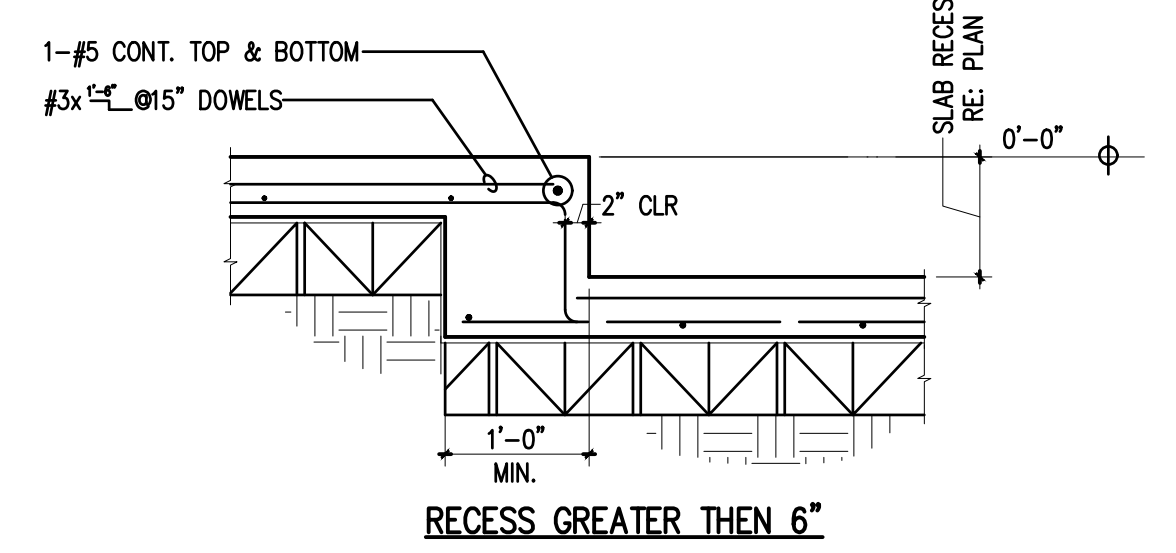

**TYPICAL SLAB RECESS DETAIL**

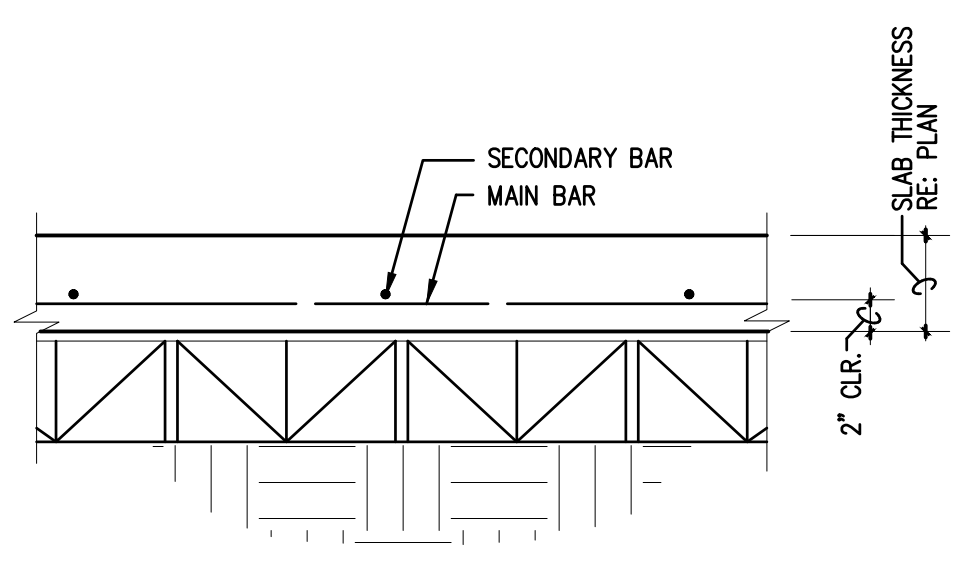

**TYPICAL SLAB REINFORCEMENT ARRANGEMENT NOT TO SCALE**

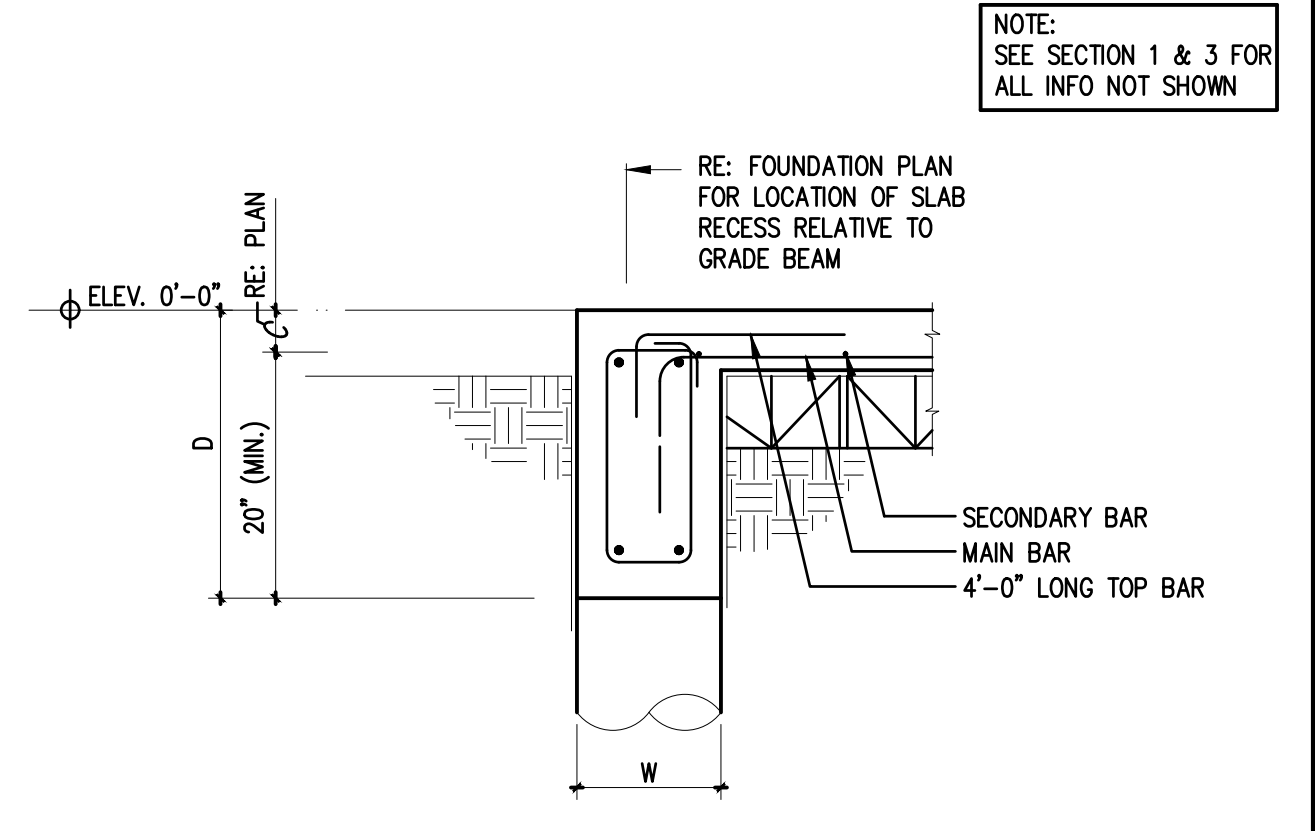

**6 SECTION: TYPICAL GRADE BEAM @ SLAB RECESS**

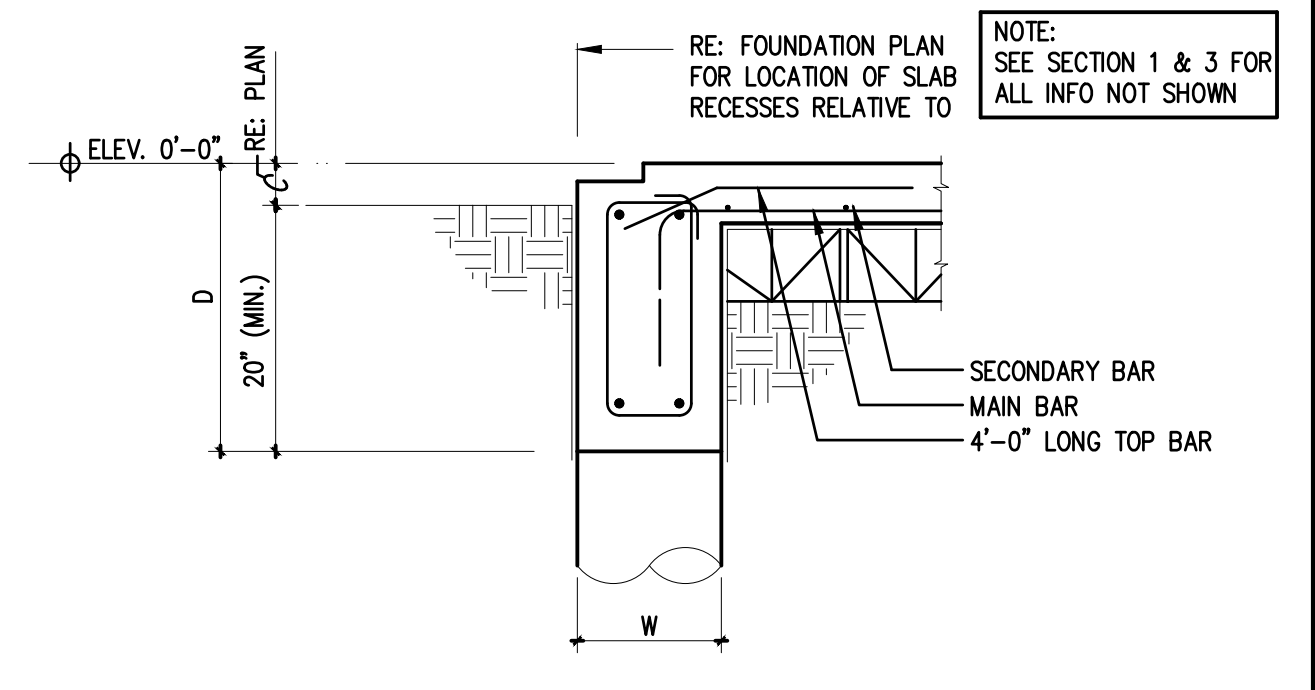

**7 SECTION: TYPICAL GRADE BEAM @ SLAB RECESS W/ BRICK**

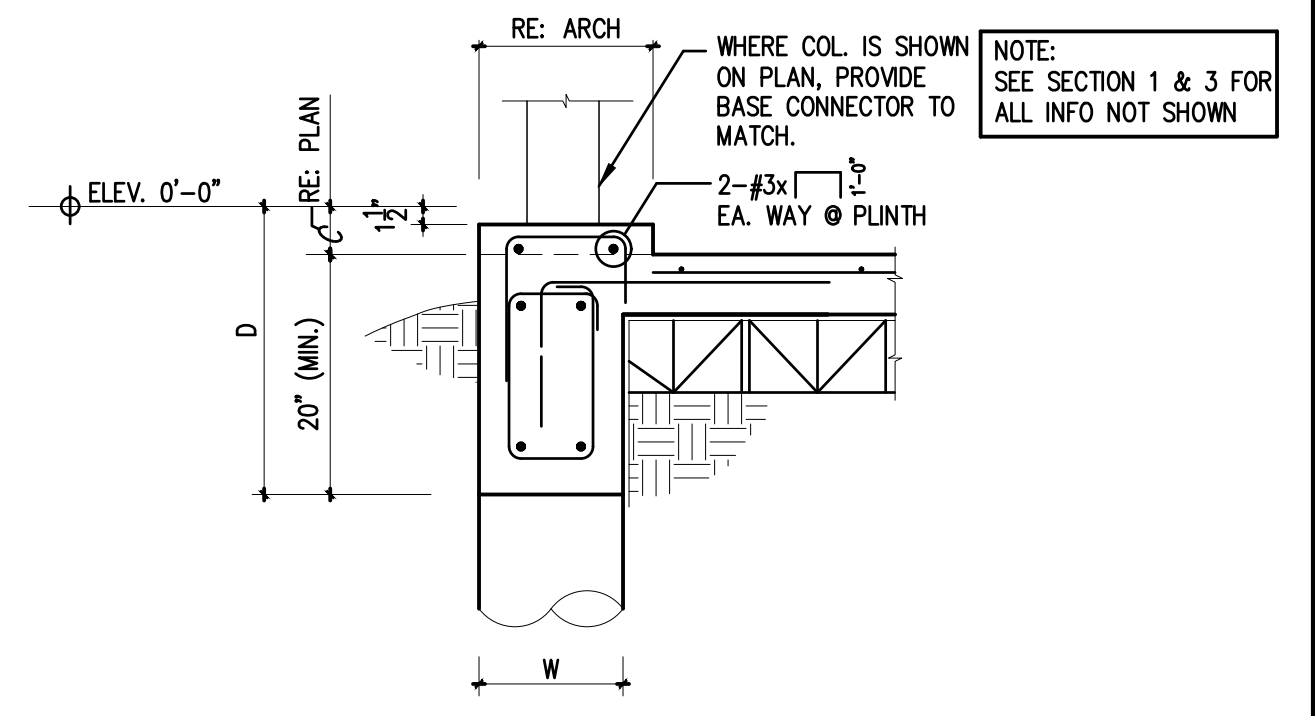

**8 SECTION: TYPICAL GRADE BEAM @ PLINTH**

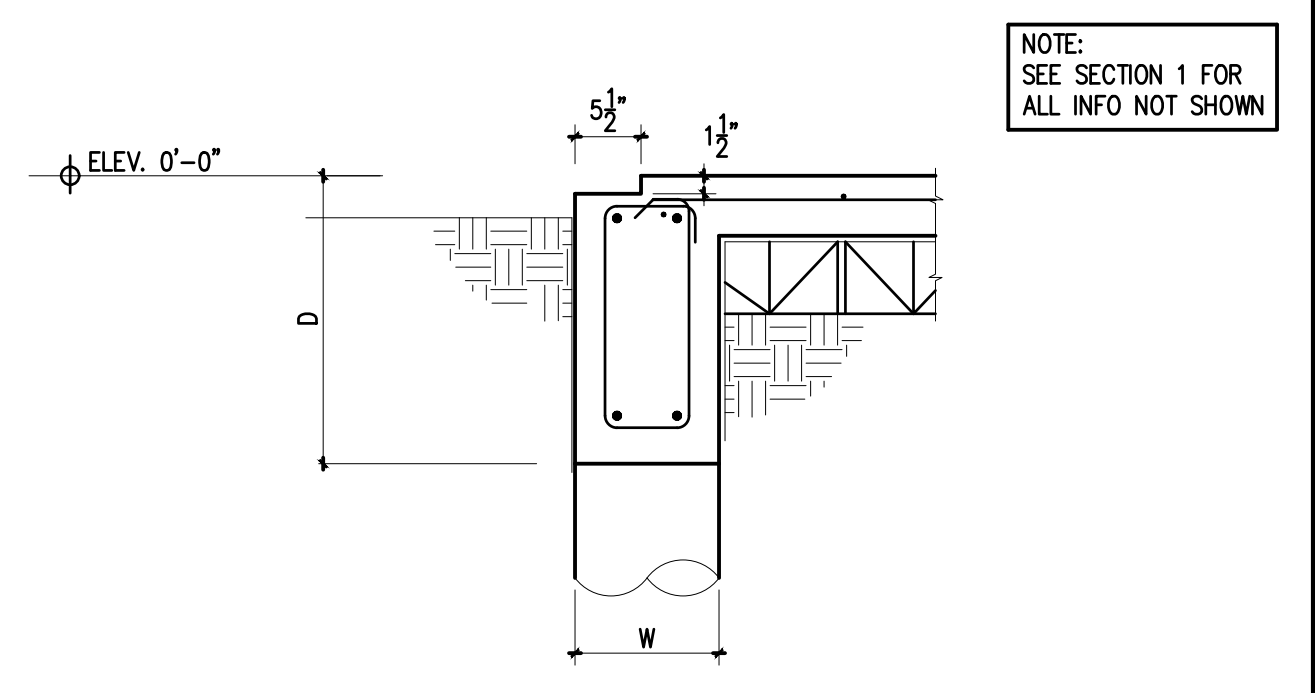

**9 SECTION: TYPICAL EXTERIOR GRADE BEAM W/ BRICK**

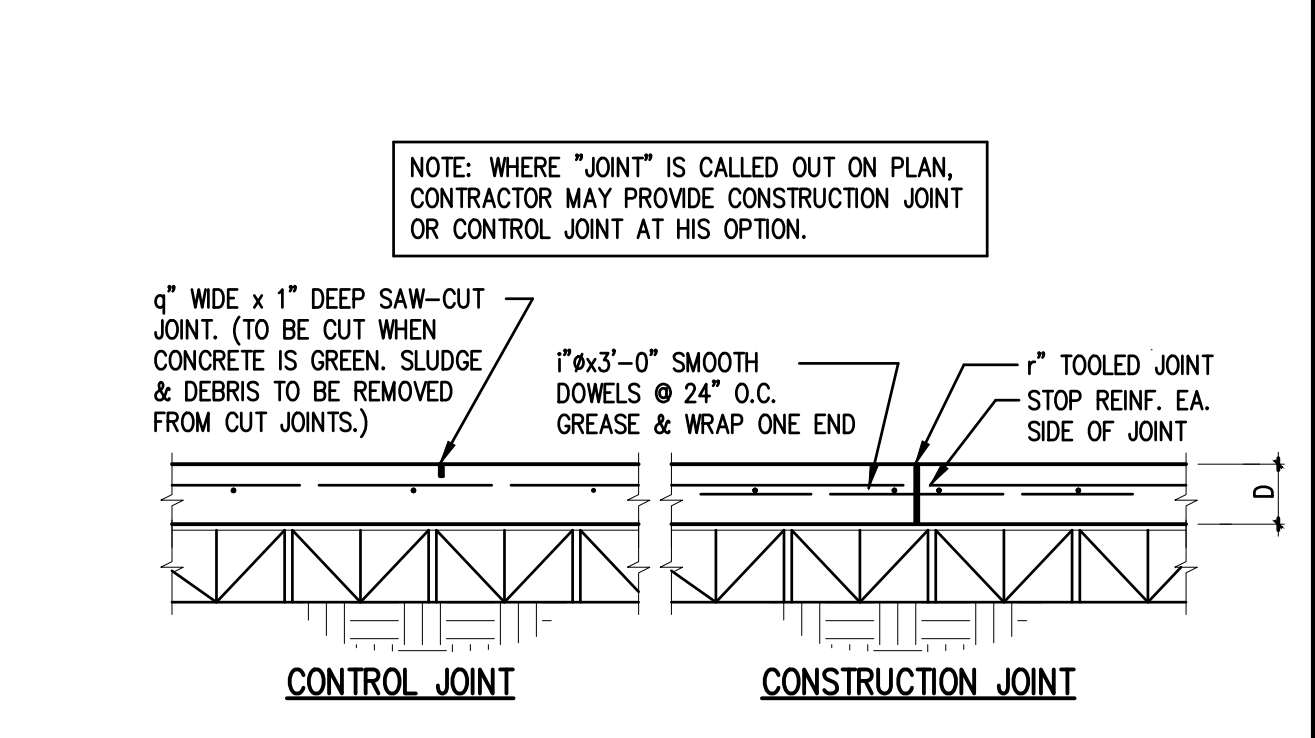

**TYPICAL SLAB JOINT DETAILS**

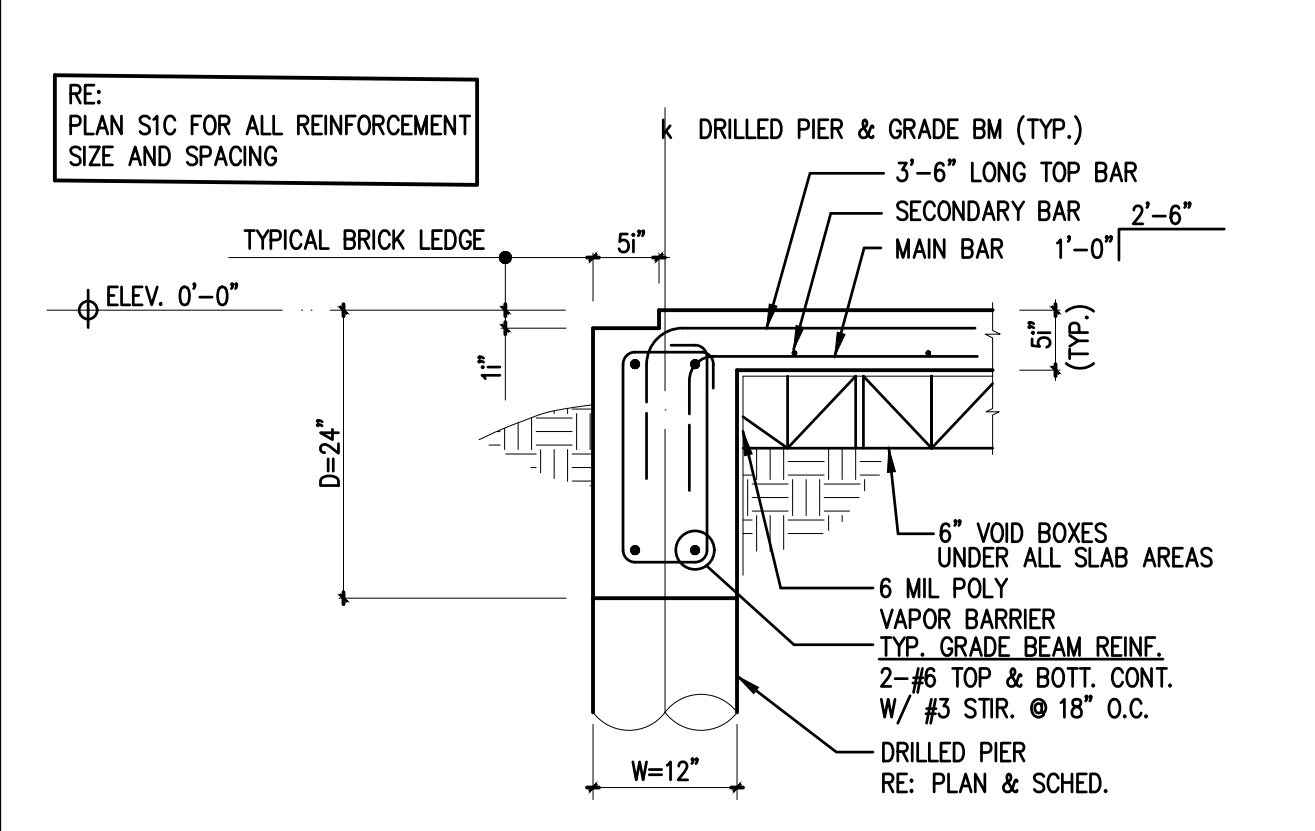

**1 SECTION: TYPICAL GRADE BEAM @ BRICK LEDGE**

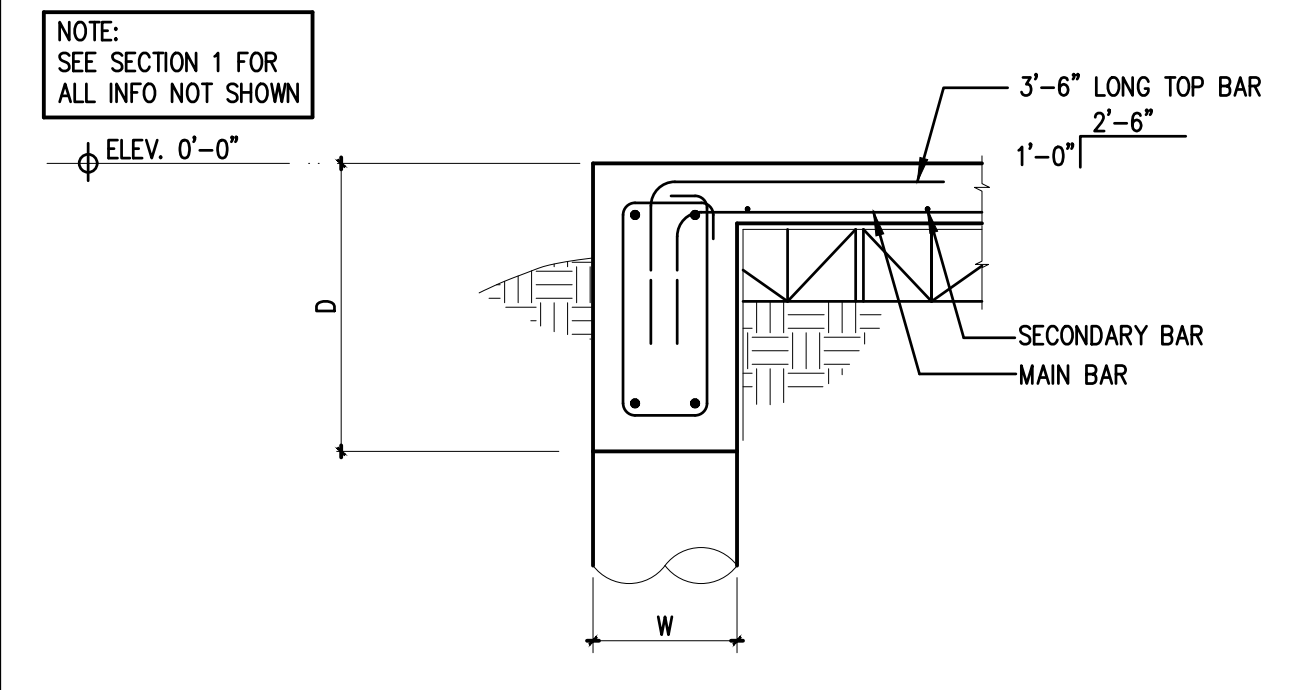

**2 SECTION: TYPICAL GRADE BEAM**

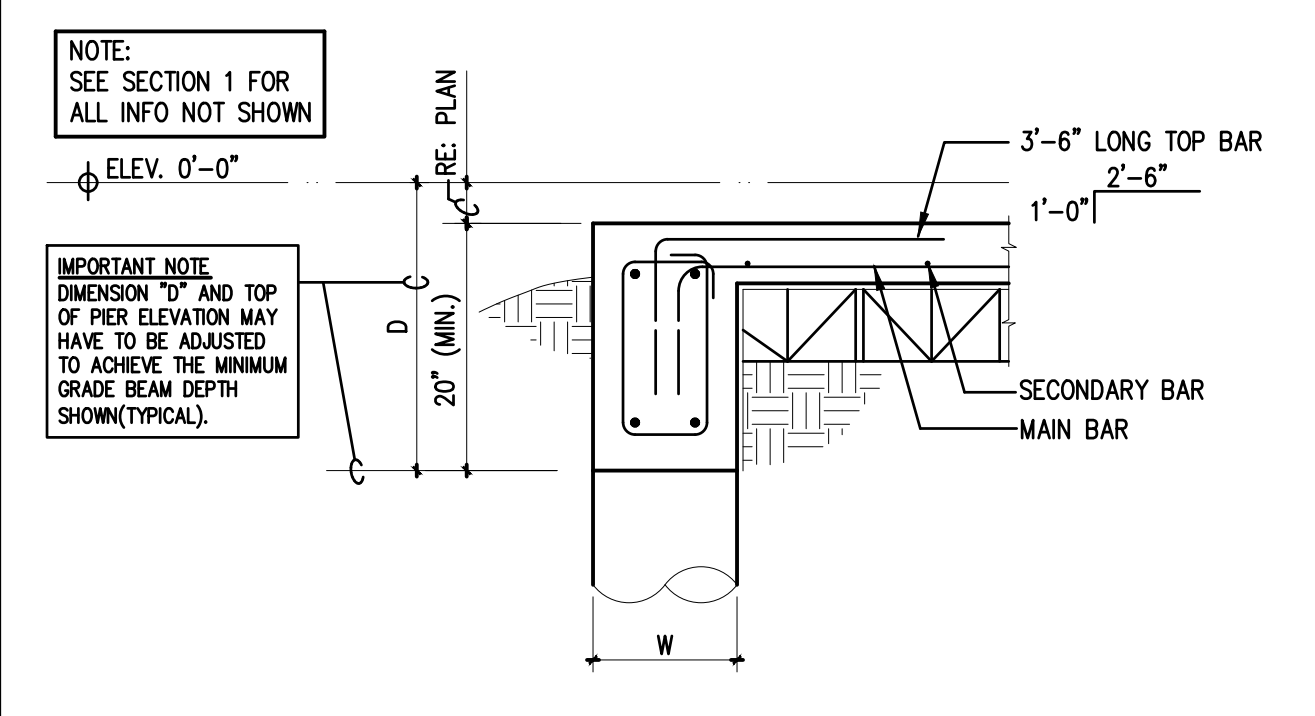

**3 SECTION: TYPICAL GRADE BEAM @ DROPPED SLAB**

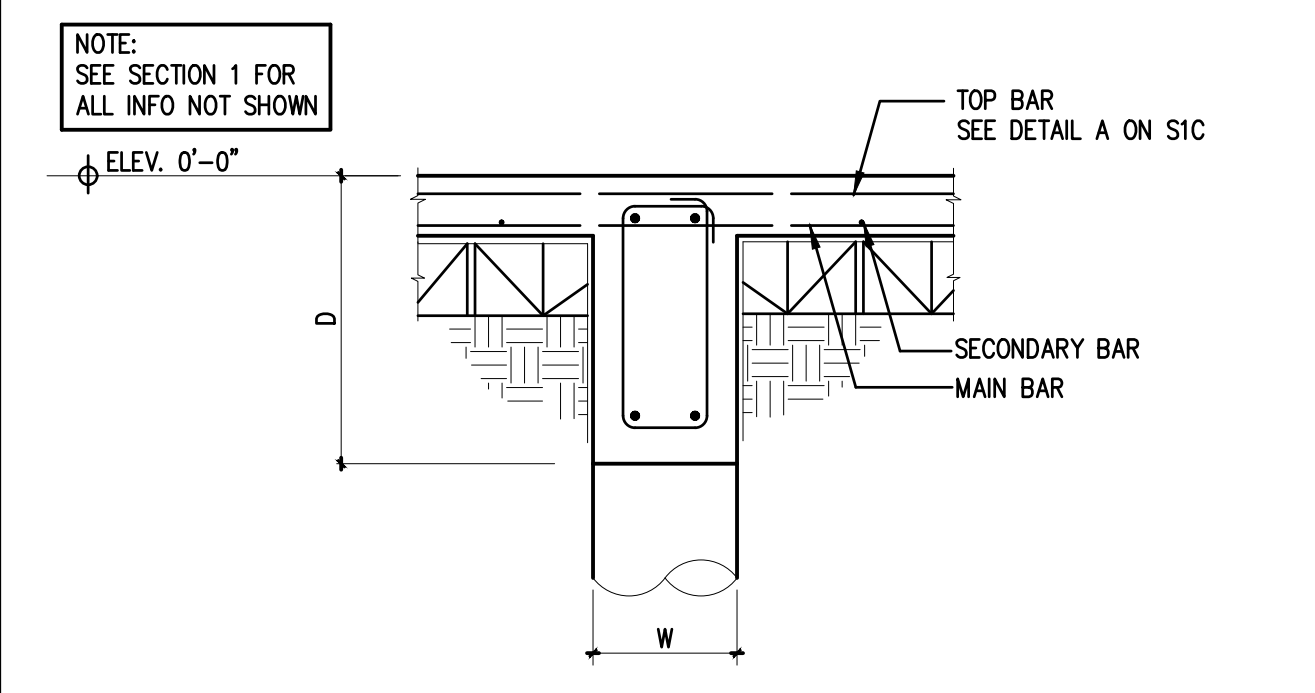

**4 SECTION: TYPICAL INTERIOR GRADE BEAM**

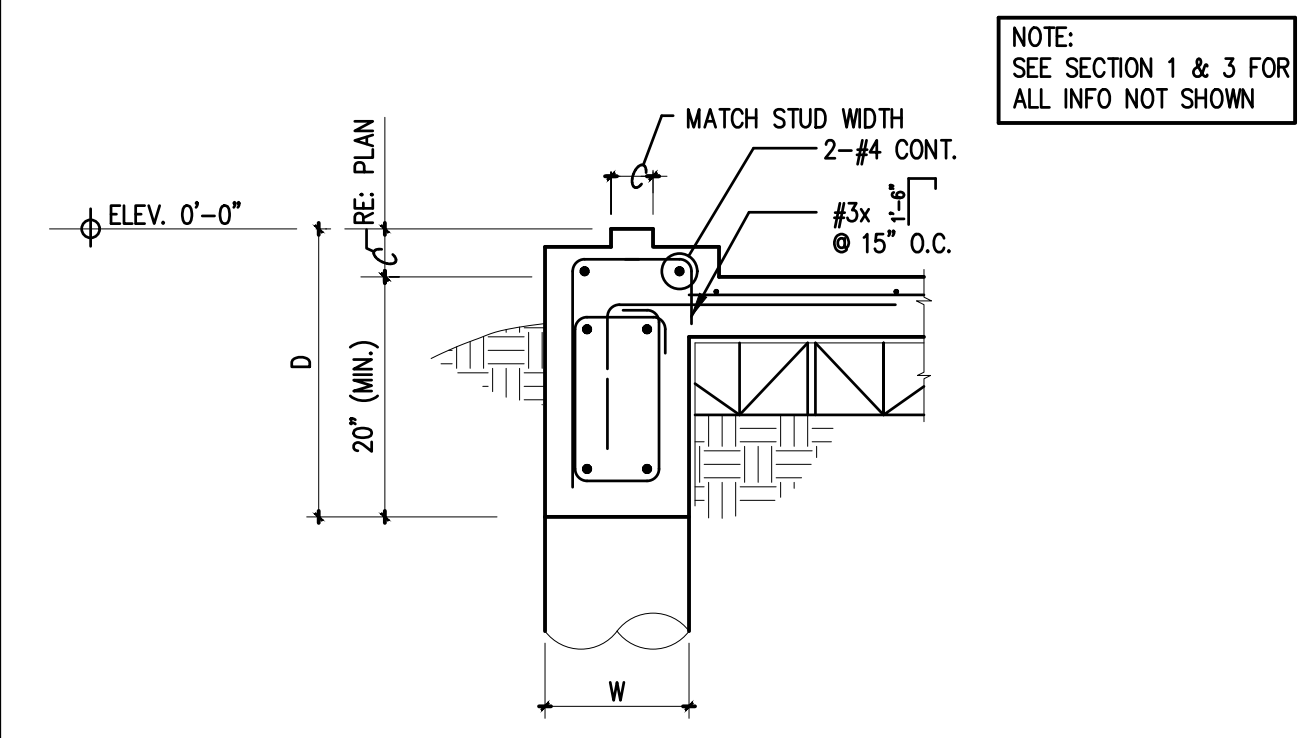

**5 SECTION: TYPICAL GRADE BEAM @ PLINTH W/ BRICK BOTH SIDES**

**FOUNDATION SECTIONS**

**OPTIMUM PERSONAL CARE PH.2**  
1110 LAKEVIEW DRIVE  
SUGAR LAND, TX. 77478

**ISSUE HISTORY**

DATE	ISSUED FOR
	CLIENT REVIEW
	PERMIT
	CONSTRUCTION

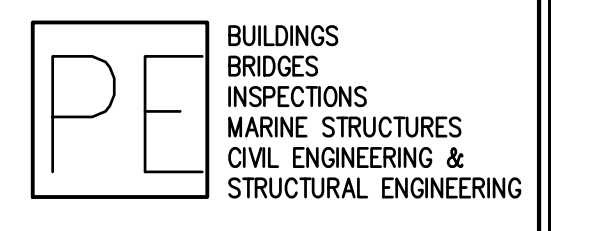

**PARAMOUNT ENGINEERING LLC**

10145 LONG POINT DR.  
HOUSTON, TX 77043  
TEL: (713) 636-9977  
FAX: (713) 888-9872  
CEL: (713) 204-1742

TBPE REGISTRATION # F-3394

DRAWN BY: E.V. CHECKED BY: M.M.

PROJ. NO.: PE12-225

SHEET: **S2**

**CEILING FRAMING PLAN**

**OPTIMUM PERSONAL CARE PH.2**

1110 LAKEVIEW DRIVE  
SUGAR LAND, TX. 77478

**ISSUE HISTORY**

DATE	ISSUED FOR
	CLIENT REVIEW
	PERMIT
	CONSTRUCTION

09/10/15

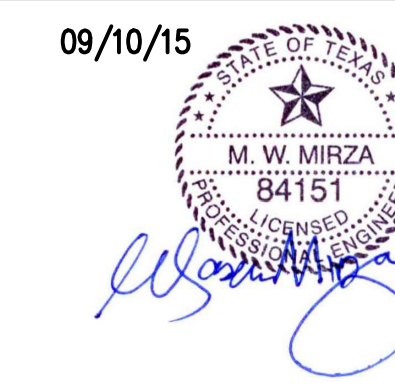

**PE** BUILDINGS  
BRIDGES  
INSPECTIONS  
MARINE STRUCTURES  
CIVIL ENGINEERING &  
STRUCTURAL ENGINEERING

**PARAMOUNT  
ENGINEERING  
LLC**

10145 LONG POINT DR.  
HOUSTON, TX 77043

TEL : (713) 636-9977  
FAX : (713) 888-9872  
CEL : (713) 204-1742

TBPE REGISTRATION # F-3394

DRAWN BY: Z.A. CHECKED BY: M.M.

PROJ. NO.: PE12-225

SHEET: **S3**

**FRAMING LEGEND**

**JOISTS**

- J612 2x6 @ 12" O.C.
- J616 2x6 @ 16" O.C.
- J619 2x6 @ 19" O.C.
- J816 2x8 @ 16" O.C.
- J1012 2x10 @ 12" O.C.
- J1016 2x10 @ 16" O.C.

**BEAM (BEAM JOIST)**

- BJ10 2x10
- BJ12 2x12
- BJ210 2- 2x10
- BJ212 2- 2x12
- BJ312 3- 2x12

**COLUMNS (WOOD COLUMNS)**

- WP44 4x4 WOOD POST
- C32-4 3-2x4 STUD
- C32-6 3-2x6 STUD

**CONNECTORS**  
(SIMPSON STRONG-TIE OR EQUAL)

- BH1 (HU 212(MAX)) BEAM HANGER
- BH2 (HUC 212(MAX)) BEAM HANGER (CONCEALED FLANGE)
- BH3 (LGU3.63-SDS) BEAM HANGER
- BH4 (MGU5.50-SDS) BEAM HANGER
- BH5 (HGUS.50-SDS-12GA.) BEAM HANGER
- BH6 (HGUS-12GA) BEAM HANGER
- BH6 (MGU3.63-SDS) BEAM HANGER
- BH7 (HHGUS.50-SDS) BEAM HANGER
- BH8 (HHGU7.25-SDS) BEAM HANGER
- BH9 (HGUS-12GA) BEAM HANGER
- WPC1 (CCQ/ECCQ) WOOD POST CAP
- WPB1 (CBQ) WOOD POST BASE

**MEMBER DESCRIPTION**

- RSB ROOF SUPPORTING BEAM
- BEAM 2.0E PARALLAM BEAM (PSL)
- BP311 3/2"x11 1/4" LSL
- BP312 3/2"x11 1/8" LSL
- BP314 3/2"x14" LSL

**PLAN LEGEND**

1. ——— DESIGNATES LOCATION OF FLOOR WALLS
2. ———> DESIGNATES DIRECTION OF CEILING JOIST
3. // // // DESIGNATES SHEAR WALL
4. P1 DESIGNATES SHEAR WALL TYPE. RE: SCHEDULE, NOTES, AND DETAILS ON SHEET S2.05.
5. ———> DESIGNATES SHEAR WALL HOLD-DOWN ANCHOR AT FLOOR LEVEL.
6. ——— DESIGNATES BEAM HANGER, IF NOT IDENTIFIED ON PLAN, USE TYPICAL HANGERS SPECIFIED IN GENERAL NOTES.
7. □ □ DESIGNATE STEEL OR WOOD COLUMNS.
8. ■ ■ ■ LOCATION OF MECH. EQUIPMENT ON CEILING

**PLAN NOTES**

1. ALL CEILING JOISTS SHALL BE #3 S.Y.P. (U.O.N.)
2. ALL FLOOR JOISTS SHALL BE #2 S.Y.P. (U.O.N.)
3. ALL BEAMS & HEADERS SHALL BE #2 S.Y.P. (U.O.N.)
4. ALL CEILING BEAMS & HEADERS SHALL BE 2-2x8 (U.O.N.)
5. ALL FLOOR BEAMS & HEADERS SHALL BE 2-2x12 (U.O.N.)
6. ALL WINDOWS & DOOR HEADERS ARE DROP BEAMS (U.O.N.)
7. ALL COLUMNS FROM FLOOR ABOVE MUST BE EITHER:  
A. SUPPORTED ON A BEAM @ THIS LEVEL.  
B. CONTINUED TO SLAB BELOW. (MATCH SIZES)
8. RE: SHEET S7.S8 FOR ALL FRAMING NOTES, DETAILS, AND SCHEDULES.

**GENERAL NOTES: COORDINATION W/ ARCH. DWGS.**

1. CONTRACTOR SHALL REVIEW ARCHITECTURAL AND STRUCTURAL DRAWINGS JOINTLY PRIOR TO CONSTRUCTION, TO ENSURE COORDINATION OF ALL PHASES OF CONSTRUCTION DESCRIBED IN THESE DRAWINGS. DISCREPANCIES SHALL BE BROUGHT TO THE ATTENTION OF BOTH ARCHITECT AND ENGINEER, PRIOR TO PROCEEDING WITH CONSTRUCTION WORK.
2. THE FOLLOWING ITEMS, IN PARTICULAR, HAVE TO BE CLOSELY COORDINATED BETWEEN ARCHITECTURAL AND STRUCTURAL DRAWINGS:  
A. ALL DIMENSIONS;  
B. SLAB AND FLOOR ELEVATIONS, SLOPES, AND LOCATION AND DIMENSIONS OF ANY RECESSES, INCLUDING THOSE INTENDED FOR SHOWERS, ELEVATORS, FLOORING MATERIALS, ETC.  
C. CURBS AND VENEER LEDGES;  
D. CEILING HEIGHTS AND CEILING CONDITIONS;  
E. ROOF GEOMETRY AND SLOPES.

ALL WALL SHALL BE 2HR FIRE-RETARDANT IN KITCHEN ONLY.

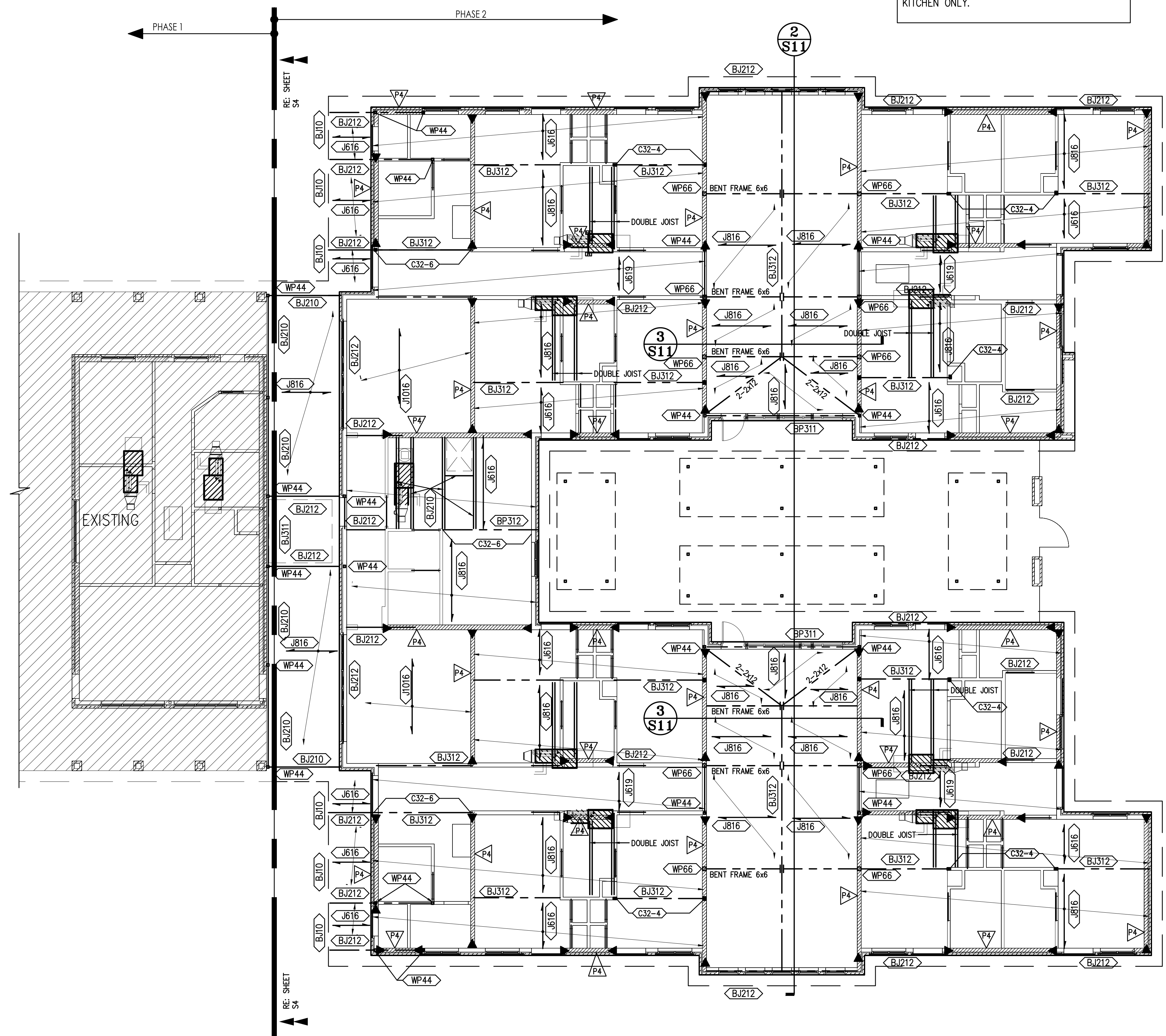

**CEILING FRAMING PLAN**  
SCALE: 1/8" = 1'-0"

CONTRACTOR TO VERIFY ALL DIMENSIONS, ELEVATIONS, AND COORDINATE DETAILS WITH ARCHITECTURAL DRAWINGS. ALL DIMENSIONS & ELEVATION ON ARCHITECTURAL DRAWINGS SHALL GOVERN. IT IS CONTRACTOR'S RESPONSIBILITY TO REPORT TO ENGINEER ABOUT DISCREPANCY IN DRAWINGS PRIOR TO FABRICATION & BIDDING.

PROVIDE 3 STUDS BOLTED TOGETHER (MATCH WALL STUD SIZE) AT EACH END OF POOR/WINDOW HEADERS.

- ALL INTERIOR WALL SHALL BE 2X4 @ 16 & EXTERIOR WALLS SHALL BE 2x6 @ 16.  
-PROVIDE 1/2 OSB/ PLYWOOD TO ALL EXTERIOR WALLS.

NOTE : REFER TO ARCHITECTURAL DRAWINGS FOR CEILING HEIGHT IN EACH AREA.

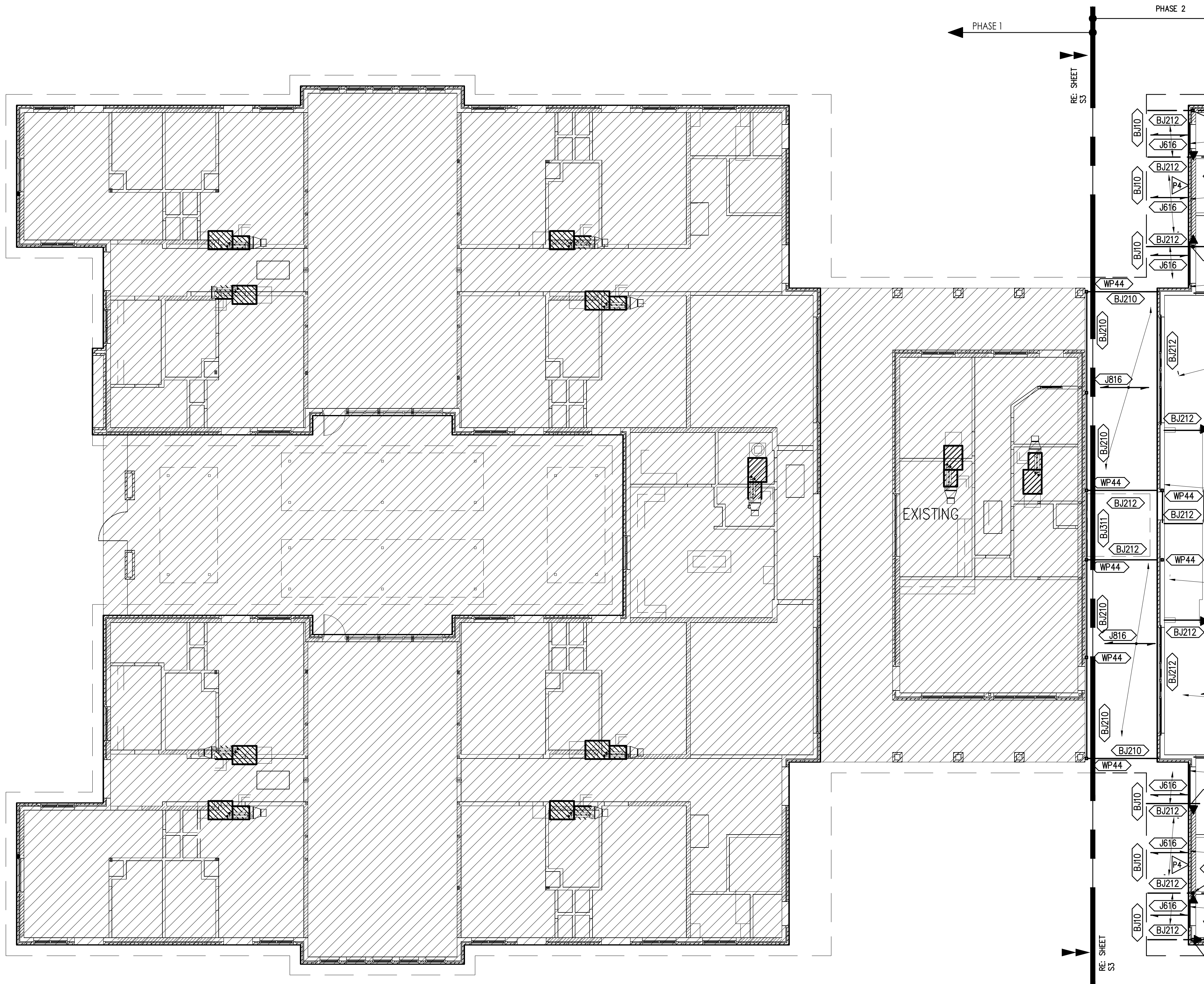

**CEILING FRAMING PLAN**  
SCALE: 1/8" = 1'-0"

CONTRACTOR TO VERIFY ALL DIMENSIONS, ELEVATIONS, AND COORDINATE DETAILS WITH ARCHITECTURAL DRAWINGS. ALL DIMENSIONS & ELEVATION ON ARCHITECTURAL DRAWINGS SHALL GOVERN. IT IS CONTRACTOR'S RESPONSIBILITY TO REPORT TO ENGINEER ABOUT DISCREPANCY IN DRAWINGS PRIOR TO FABRICATION & BIDDING.

PROVIDE 3 STUDS BOLTED TOGETHER (MATCH WALL STUD SIZE) AT EACH END OF POOR/WINDOW HEADERS.

NOTE : REFER TO ARCHITECTURAL DRAWINGS FOR CEILING HEIGHT IN EACH AREA.

- FRAMING LEGEND**
- JOISTS**
- J612 2x6 @ 12" O.C.
  - J616 2x6 @ 16" O.C.
  - J619 2x6 @ 19" O.C.
  - J816 2x8 @ 16" O.C.
  - J1012 2x10 @ 12" O.C.
  - J1016 2x10 @ 16" O.C.
- BEAM (BEAM JOIST)**
- BJ210 2- 2x10
  - BJ10 2x10
  - BJ12 2x12
  - BJ212 2- 2x12
  - BJ312 3- 2x12
- COLUMNS**
- W6x24 6x24 STEEL COLUMN
  - WP44 4x4 WOOD POST
  - C32-4 3-2x4 STUD
  - C32-6 3-2x6 STUD
- CONNECTORS**  
(SIMPSON STRONG-TIE OR EQUAL)
- BH1 (HU 212(MAX)) BEAM HANGER
  - BH2 (HUC 212(MAX)) BEAM HANGER (CONCEALED FLANGE)
  - BH3 (LGU3.63-SDS) BEAM HANGER
  - BH4 (MGU5.50-SDS) BEAM HANGER
  - BH5 (HGUS.50-SDS-12GA.) BEAM HANGER
  - BH6 (HGUS-12GA) BEAM HANGER
  - BH6 (MGU3.63-SDS) BEAM HANGER
  - BH7 (HHGU5.50-SDS) BEAM HANGER
  - BH8 (HHGU7.25-SDS) BEAM HANGER
  - BH9 (HGUS-12GA) BEAM HANGER
  - WPC1 (CCQ/ECCQ) WOOD POST CAP
  - WPB1 (CBQ) WOOD POST BASE
- MEMBER DESCRIPTION**
- RSB ROOF SUPPORTING BEAM
  - BEAM 2.0E PARALLAM BEAM (PSL)
  - BP311 3 1/2"x11" LSL
  - BP312 3 1/2"x11 1/2" LSL
  - BP314 3 1/2"x14" LSL

- PLAN NOTES**
1. ALL CEILING JOISTS SHALL BE #3 S.Y.P. (U.O.N.)
  2. ALL FLOOR JOISTS SHALL BE #2 S.Y.P. (U.O.N.)
  3. ALL BEAMS & HEADERS SHALL BE #2 S.Y.P. (U.O.N.)
  4. ALL CEILING BEAMS & HEADERS SHALL BE 2-2x8 (U.O.N.)
  5. ALL FLOOR BEAMS & HEADERS SHALL BE 2-2x12 (U.O.N.)
  6. ALL WINDOWS & DOOR HEADERS ARE DROP BEAMS (U.O.N.)
  7. TRUSS SUPPLIER MAY CHOOSE PARALLAM OR GLU-LAM BEAMS INSTEAD OF TRUSSES UNDER SOME LOAD BEARING WALLS. IN THIS CASE, BEAM DESIGN SHALL BE BY TRUSS MANUFACTURER, WHO SHALL ALSO DESIGNATE REQUIRED COLUMNS UNDER THESE BEAMS. (RE: COLUMN SCHEDULE.)
  8. ALL COLUMNS FROM FLOOR ABOVE MUST BE EITHER:
    - A. SUPPORTED ON A BEAM @ THIS LEVEL.
    - B. CONTINUED TO SLAB BELOW. (MATCH SIZES)
  9. RE: SHEETS S7-S8 FOR FRAMING GENERAL NOTES, TYP. DETAILS & SCHEDULES.

- GENERAL NOTES: COORDINATION W/ ARCH. DWGS.**
1. CONTRACTOR SHALL REVIEW ARCHITECTURAL AND STRUCTURAL DRAWINGS JOINTLY PRIOR TO CONSTRUCTION, TO ENSURE COORDINATION OF ALL PHASES OF CONSTRUCTION DESCRIBED IN THESE DRAWINGS. DISCREPANCIES SHALL BE BROUGHT TO THE ATTENTION OF BOTH ARCHITECT AND ENGINEER, PRIOR TO PROCEEDING WITH CONSTRUCTION WORK.
  2. THE FOLLOWING ITEMS, IN PARTICULAR, HAVE TO BE CLOSELY COORDINATED BETWEEN ARCHITECTURAL AND STRUCTURAL DRAWINGS:
    - A. ALL DIMENSIONS;
    - B. SLAB AND FLOOR ELEVATIONS, SLOPES, AND LOCATION AND DIMENSIONS OF ANY RECESSES, INCLUDING THOSE INTENDED FOR SHOWERS, ELEVATORS, FLOORING MATERIALS, ETC.
    - C. CURBS AND VENEER LEDGES;
    - D. CEILING HEIGHTS AND CEILING CONDITIONS;
    - E. ROOF GEOMETRY AND SLOPES.

**IMPORTANT NOTE:**  
ALL EXTERIOR WALL SHALL BE SHEATED WITH 1/2" PLYWOOD OR OSB.

- STUD WALL SCHEDULE**
- 2x4 @ 16" O.C. STUD WALL & SHEAR WALL INTERIOR.
  - 2x6 @ 16" O.C. EXTERIOR SHEAR WALL.
- NOTE: ALL EXTERIOR WALLS SHALL BE 2x6 @ 16" O.C. STUD WALL

- PLAN LEGEND**
1. ——— DESIGNATES LOCATION OF FLOOR WALLS
  2. ———> DESIGNATES DIRECTION OF CEILING JOIST
  3. ———/——— DESIGNATES SHEAR WALL
  4. P1 DESIGNATES SHEAR WALL TYPE. RE: SCHEDULE, NOTES, AND DETAILS ON SHEET S2.05.
  5. ———> DESIGNATES SHEAR WALL HOLD-DOWN ANCHOR AT FLOOR LEVEL.
  6. ———> DESIGNATES BEAM HANGER, IF NOT IDENTIFIED ON PLAN, USE TYPICAL HANGERS SPECIFIED IN GENERAL NOTES.
  7. □ □ DESIGNATE STEEL OR WOOD COLUMNS.
  8. [Hatched Box] LOCATION OF MECH. EQUIPMENT ON CEILING

**CEILING FRAMING PLAN**

**OPTIMUM PERSONAL CARE PH.2**  
1110 LAKEVIEW DRIVE  
SUGAR LAND, TX. 77478

**ISSUE HISTORY**

DATE	ISSUED FOR
	CLIENT REVIEW
	PERMIT
	CONSTRUCTION

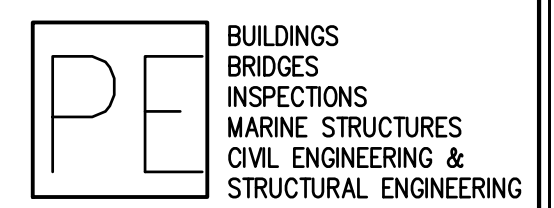

**PARAMOUNT ENGINEERING LLC**

10145 LONG POINT DR.  
HOUSTON, TX 77043  
TEL : (713) 636-9977  
FAX : (713) 888-9872  
CEL : (713) 204-1742

TBPE REGISTRATION # F-3394

DRAWN BY: E.V. H.P. CHECKED BY: M.M.

PROJ. NO.: PE12-225

SHEET: **S4**

**ROOF FRAMING PLAN**

**OPTIMUM PERSONAL CARE PH.2**

1110 LAKEVIEW DRIVE  
SUGAR LAND, TX. 77478

**ISSUE HISTORY**

DATE	ISSUED FOR
	CLIENT REVIEW
	PERMIT
	CONSTRUCTION

09/10/15

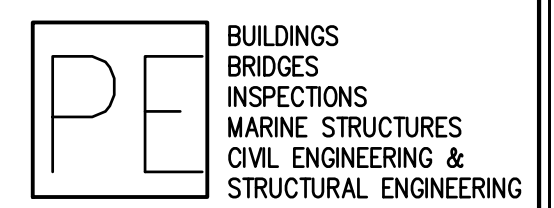
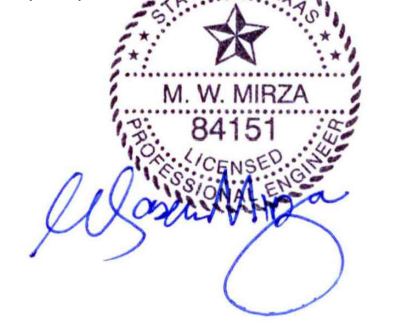

**PARAMOUNT ENGINEERING LLC**

10145 LONG POINT DR.  
HOUSTON, TX 77043  
TEL : (713) 636-9977  
FAX : (713) 888-9872  
CEL : (713) 204-1742

TBPE REGISTRATION # F-3394

DRAWN BY: Z.A. CHECKED BY: M.M.

PROJ. NO.: PE12-225

SHEET: **S5**

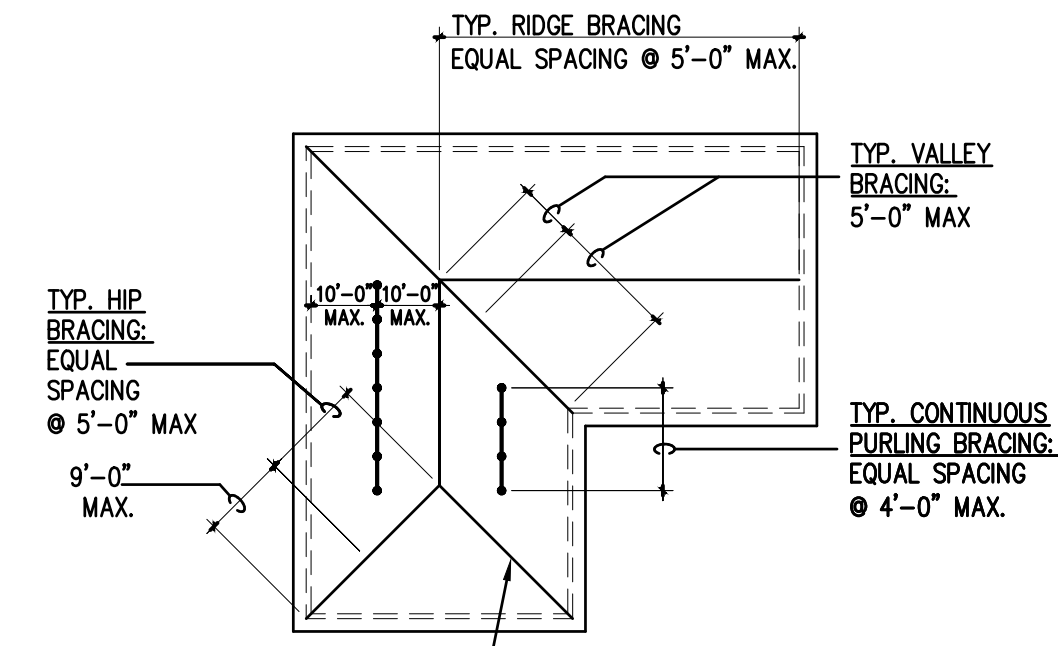

**DIAGRAM: TYPICAL BRACE LOCATIONS**  
(NOT TO SCALE)

**PLAN NOTES**

- ROOF FRAMING IS DESIGNED FOR COMPOSITION SHINGLE ROOF @ 6.5 PSF.
- DESIGNATES BRACE (APPROXIMATELY IN THE INDICATED DIRECTION)
- INDICATES A VERTICAL (OR NEARLY VERTICAL) BRACE TO SUPPORTING MEMBER BELOW.
- BRACE SUPPORT DESIGNATION:  
(ALL BRACING TO WALLS UNLESS OTHERWISE NOTED)  
EM BRACE TO BEAM  
ES BRACE TO STRONGBACK  
EW BRACE TO WALL
- ALL RAFTERS ARE 2x6 #3 S.Y.P. AT 16" O.C. U.O.N.
- PURLINS SHALL BE 2x6 CONTINUOUS MEMBER.
- DEPTH OF RIDGE BEAM, HIP OR VALLEY RAFTER:  
A. SHALL BE ONE SIZE WIDER THAN THE LARGEST RAFTER FRAMING INTO IT (EXAMPLE: 2x8 BEAM FOR 2x6 RAFTER); U.O.N.  
B. SHALL MATCH OR EXCEED THE CUT END OF THE RAFTER.
- PROVIDE DOUBLE FRAMING @ EDGES OF ALL ROOF OPENINGS LARGER THAN 24".
- PROVIDE DOUBLE RAFTERS UNDER ALL DORMER WALL (U.O.N.).
- ROOF DECKING TO BE 1/2" C.D.X. WITH PANEL SPAN RATING OF 24-0.  
RE: GENERAL NOTES FOR OTHER REQUIREMENTS.
- RAFTERS SHALL BE NAILED TO ADJACENT CEILING JOISTS TO FORM A CONTINUOUS TIE BETWEEN EXTERIOR WALLS WHEN SUCH JOISTS ARE PARALLEL TO THE RAFTERS. WHERE NOT PARALLEL, RAFTER TIES SHALL BE SPACED NOT MORE THAN 48" O.C.
- PROVIDE 2x6 COLLAR TIES AT EVERY OTHER RAFTER (UPPER 1/2 OF ROOF).
- RE: ARCH. DWGS FOR ROOF SLOPES & OTHER DATA NOT CONTAINED HEREIN.
- RE: SHEETS S7-S8 FOR FRAMING GENERAL NOTES, TYP. DETAILS & SCHEDULES.

**GENERAL NOTES: COORDINATION W/ ARCH. DWGS.**

- CONTRACTOR SHALL REVIEW ARCHITECTURAL AND STRUCTURAL DRAWINGS JOINTLY PRIOR TO CONSTRUCTION, TO ENSURE COORDINATION OF ALL PHASES OF CONSTRUCTION DESCRIBED IN THESE DRAWINGS. DISCREPANCIES SHALL BE BROUGHT TO THE ATTENTION OF BOTH ARCHITECT AND ENGINEER, PRIOR TO PROCEEDING WITH CONSTRUCTION WORK.
- THE FOLLOWING ITEMS, IN PARTICULAR, HAVE TO BE CLOSELY COORDINATED BETWEEN ARCHITECTURAL AND STRUCTURAL DRAWINGS:  
A. ALL DIMENSIONS;  
B. SLAB AND FLOOR ELEVATIONS, SLOPES, AND LOCATION AND DIMENSIONS OF ANY RECESSES, INCLUDING THOSE INTENDED FOR SHOWERS, ELEVATORS, FLOORING MATERIALS, ETC.  
C. CURBS AND VENEER LEDGES;  
D. CEILING HEIGHTS AND CEILING CONDITIONS;  
E. ROOF GEOMETRY AND SLOPES.
- IT'S THE OWNER'S RESPONSIBILITY TO HIRE A REPUTABLE CONTRACTOR WHO CAN COORDINATE BETWEEN ARCHITECTURAL & STRUCTURAL DRAWINGS FOR ACCURACY

ROOF SLOPE = SEE ARCH.  
COORDINATE ROOF SLOPE & GEOMETRY W/ ARCH. DRAWINGS,  
WHICH TAKE PRECEDENCE OVER ANY SUCH INFORMATION SHOWN HEREIN.

VERIFY ALL SLOPES & ELEVATION  
WITH ARCHITECTURAL DRAWINGS  
PRIOR TO CONSTRUCTION

- ① RIDGE 2-2x8
- ② HIP 2-2x8
- ③ VALEY 2-2x8

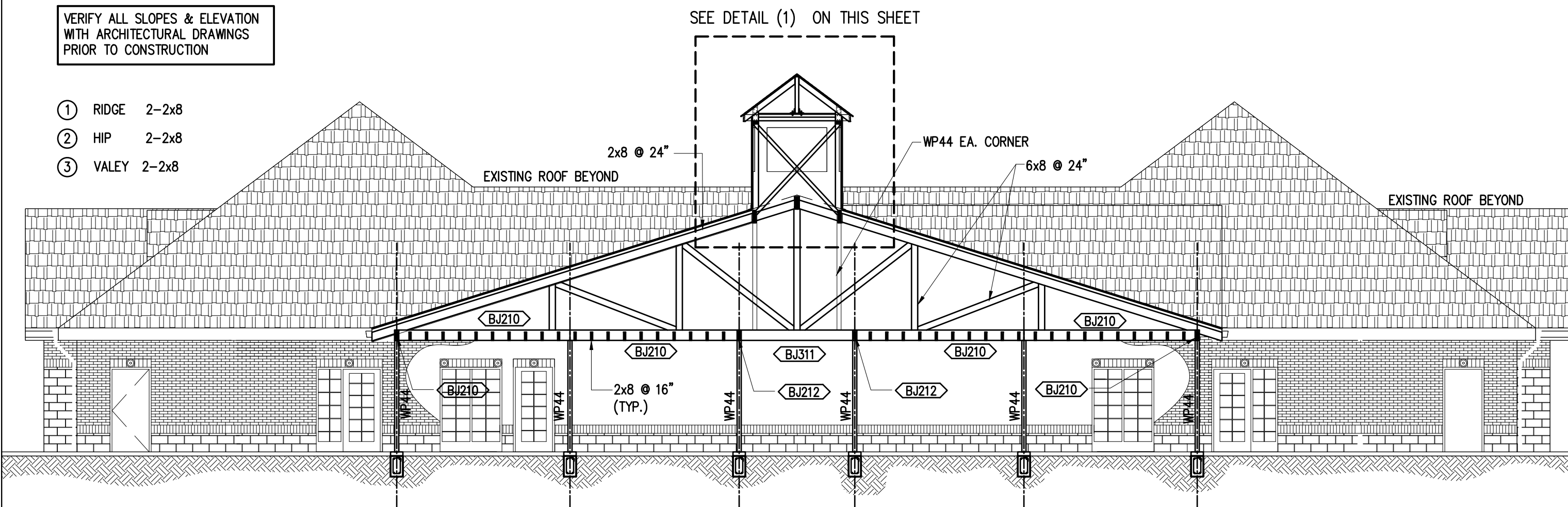

**1 SECTION: AREA BETWEEN PHASE1 & 2**

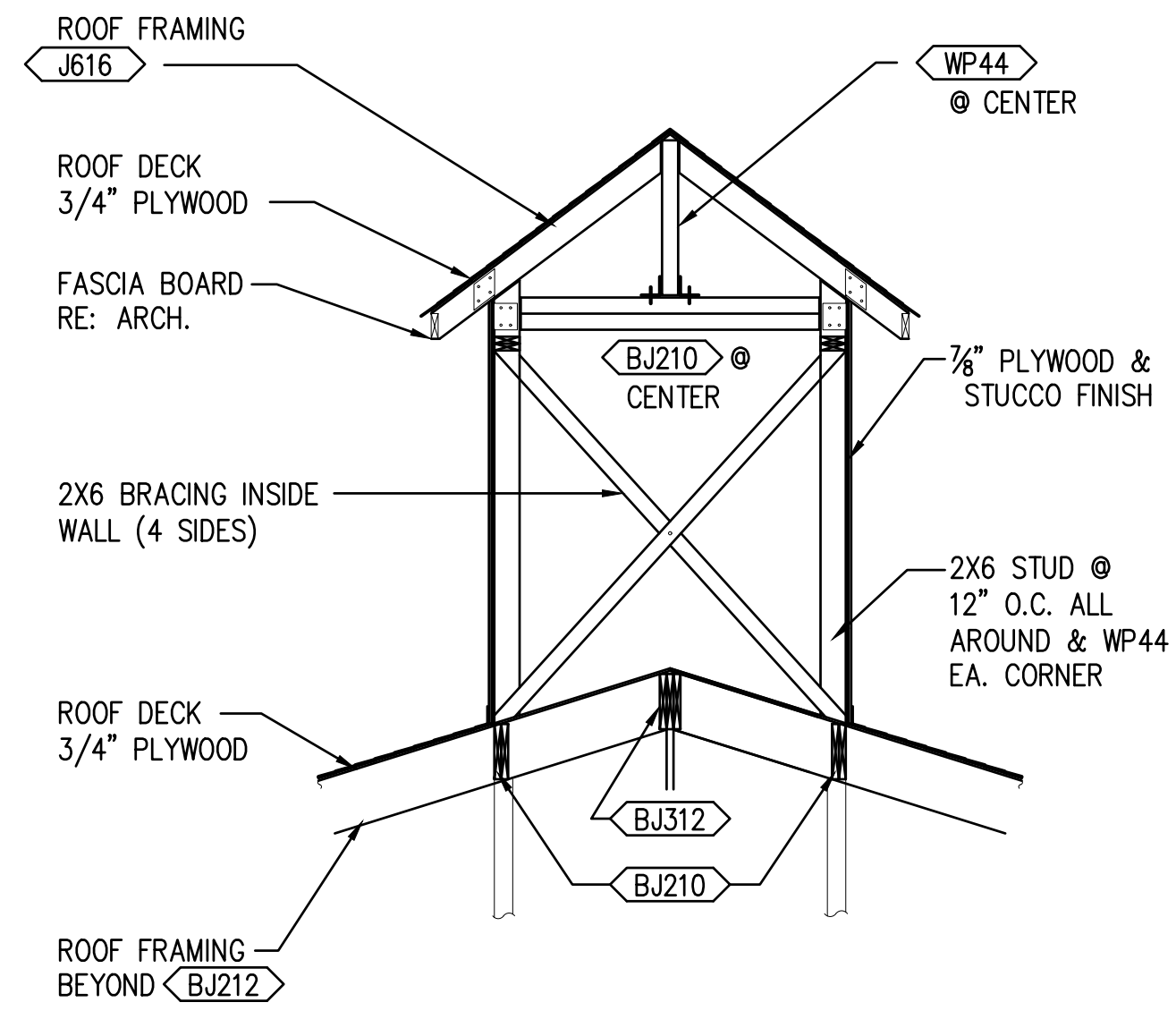

**1 DETAIL: AT TOWER**

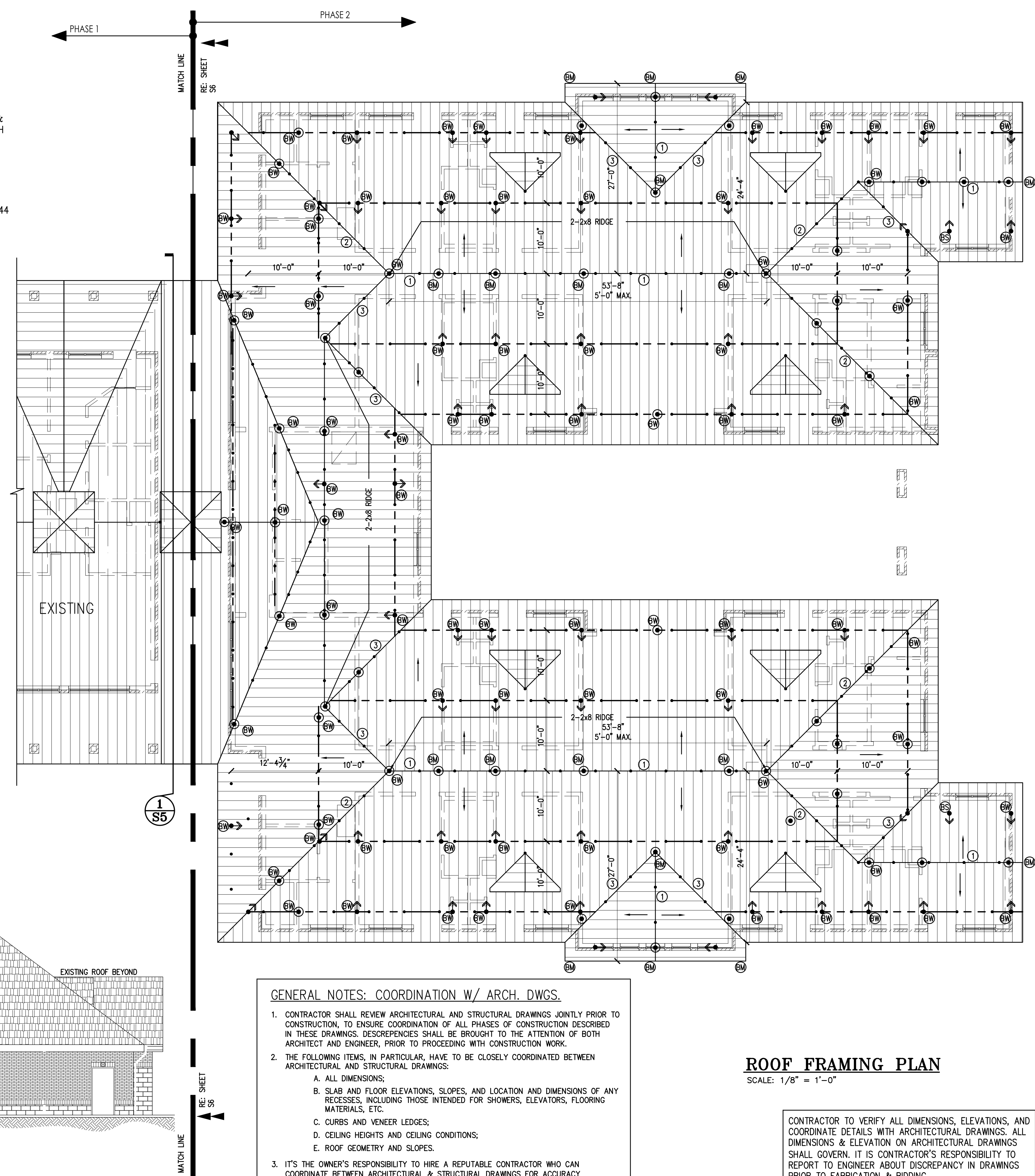

**GENERAL NOTES: COORDINATION W/ ARCH. DWGS.**

- CONTRACTOR SHALL REVIEW ARCHITECTURAL AND STRUCTURAL DRAWINGS JOINTLY PRIOR TO CONSTRUCTION, TO ENSURE COORDINATION OF ALL PHASES OF CONSTRUCTION DESCRIBED IN THESE DRAWINGS. DISCREPANCIES SHALL BE BROUGHT TO THE ATTENTION OF BOTH ARCHITECT AND ENGINEER, PRIOR TO PROCEEDING WITH CONSTRUCTION WORK.
- THE FOLLOWING ITEMS, IN PARTICULAR, HAVE TO BE CLOSELY COORDINATED BETWEEN ARCHITECTURAL AND STRUCTURAL DRAWINGS:  
A. ALL DIMENSIONS;  
B. SLAB AND FLOOR ELEVATIONS, SLOPES, AND LOCATION AND DIMENSIONS OF ANY RECESSES, INCLUDING THOSE INTENDED FOR SHOWERS, ELEVATORS, FLOORING MATERIALS, ETC.  
C. CURBS AND VENEER LEDGES;  
D. CEILING HEIGHTS AND CEILING CONDITIONS;  
E. ROOF GEOMETRY AND SLOPES.
- IT'S THE OWNER'S RESPONSIBILITY TO HIRE A REPUTABLE CONTRACTOR WHO CAN COORDINATE BETWEEN ARCHITECTURAL & STRUCTURAL DRAWINGS FOR ACCURACY

**ROOF FRAMING PLAN**

SCALE: 1/8" = 1'-0"

CONTRACTOR TO VERIFY ALL DIMENSIONS, ELEVATIONS, AND COORDINATE DETAILS WITH ARCHITECTURAL DRAWINGS. ALL DIMENSIONS & ELEVATION ON ARCHITECTURAL DRAWINGS SHALL GOVERN. IT IS CONTRACTOR'S RESPONSIBILITY TO REPORT TO ENGINEER ABOUT DISCREPANCY IN DRAWINGS PRIOR TO FABRICATION & BIDDING.



**GENERAL NOTES FOR WOOD FRAMING**

(THESE NOTES SHALL CONTROL UNLESS NOTED OTHERWISE ON PLANS AND DETAILS.)

**TIMBER GRADES**

CEILING AND FLOOR JOISTS:—NO. 2 SOUTHERN YELLOW PINE (SYP) OR EQUAL  
 BEAMS & HEADERS:—NO. 2 SOUTHERN YELLOW PINE (SYP) OR EQUAL  
 STUDS:—STUD GRADE (SYP) OR EQUAL  
 WOOD POSTS:—NO. 2 SYP, SURFACE GREEN.

**JOISTS**

- JOIST BLOCKING**
  - JOISTS SHALL BE LATERALLY SUPPORTED AT EACH END AND AT EACH SUPPORT BY SOLID BLOCKING EXCEPT WHERE THE ENDS OF JOISTS ARE NAILED INTO A HEADER, BAND OR RIM JOIST OR TO AN ADJOINING STUD. SOLID BLOCKING SHALL NOT BE LESS THAN TWO INCHES IN THICKNESS AND SHALL MATCH THE DEPTH OF THE JOIST.
  - PROVIDE SOLID BLOCKING UNDER ALL BEARING WALLS PERPENDICULAR TO THE DIRECTION OF THE JOISTS.
  - PROVIDE DOUBLE JOISTS UNDER ALL BEARING WALLS PARALLEL TO THE DIRECTION OF THE JOISTS.

**JOIST BRIDGING**

PROVIDE BRIDGING AT ALL FLOOR JOISTS AT SPACING NOT TO EXCEED 8'-0".

**JOIST HOLES AND NOTCHES**

- NOTCHES IN TOP OR BOTTOM OF JOISTS SHALL NOT EXCEED ONE SIXTH (1/6) THE JOIST DEPTH AND SHALL NOT BE LOCATED WITHIN MIDDLE THIRD OF THE SPAN.
- HOLES SHALL NOT BE CLOSER THAN 2" TO TOP OR BOTTOM OF JOIST, THE DIAMETER OF ANY HOLE SHALL NOT EXCEED ONE FOURTH (1/4) THE JOIST DEPTH UNLESS APPROVED BY THE ENGINEER.

**BEAMS AND HEADERS**

- AT BEAMS MADE UP OF A NUMBER OF 2x JOISTS, EACH JOIST WILL BEAR ON A WALL STUD (I.E. NUMBER OF WALL STUDS SHALL MATCH NUMBER OF JOISTS BEARING ON THESE STUDS). THE CENTERLINE OF THE BEAM SHALL BE THE CENTERLINE OF THE SUPPORTING WALL STUDS.
- ALL BEAMS MADE UP OF A NUMBER OF 2x JOISTS SHALL BE FASTENED AS FOLLOWS: FOR THE MAXIMUM HORIZONTAL SPACING OF BOLTS:  
 2-2x12 — 16d NAILS @ 12" TOP & BOTTOM, STAGGER, EA. FACE  
 3-2x12 — 20d NAILS @ 12" TOP & BOTTOM, STAGGER, EA. FACE  
 4-2x12 (OR MORE) — 5/8" BOLTS @ 12" TOP & BOTTOM, STAGGER  
 BOLTS SHALL BE 5/8" LOCATED 2" MINIMUM FROM BEAM EDGES AND SHALL BE STAGGERED IN TOP AND BOTTOM ROWS. PROVIDE STANDARD WASHERS @ EACH FACE.
- ALL DOOR AND WINDOW HEADERS (OR HEADERS AT ANY OTHER OPENING) THAT ARE NOT SPECIFIED ON PLANS SHALL BE AS FOLLOWS:  
 FLOOR FRAMING: 2-2x12  
 CEILING FRAMING: 2-2x8  
 MINIMUM BEARING OF ANY BEAM OR HEADER AT A STUD WALL IS 3-1/2"

**STUD WALLS**

- STUDS SHALL BE AS FOLLOWS:  
 2x4 @ 16"
- PROVIDE A MINIMUM OF TWO (2) STUDS AT EACH SIDE OF OPENINGS LARGER THAN 4'-0", FULL HEIGHT OF WALL (KING STUDS).
- MAXIMUM STUD WALL HEIGHT SHALL BE AS FOLLOWS:  
 2x4 STUDS @ 16" O.C. 10'-0"  
 2x6 STUDS @ 16" O.C. 13'-0"  
 2x8 STUDS @ 16" O.C. 13'-0" TO 18'-0"
- BLOCKING & LATERAL BRACING:
  - PROVIDE BLOCKING AND/OR TEMPORARY CROSS BRACING AS REQUIRED TO ENSURE STUD STRAIGHTNESS ACCORDING TO SPECIFIED TOLERANCES.
  - MAXIMUM TOLERANCE FOR STUD STRAIGHTNESS IN EITHER DIRECTION IS 1/4 INCH PER TEN (10) FEET OF STUD HEIGHT.
  - MINIMUM BLOCKING:
    - 1 ROW FOR STUD HEIGHT UP TO 9'-0";
    - 2 ROWS FOR STUD HEIGHT UP TO 15'-0";
    - 3 ROWS FOR STUD HEIGHT OVER 15'-0".

**PLYWOOD FLOOR DECK:**

- PLYWOOD SHALL BE 1-1/8" THICKNESS AND SHALL BE RATED STURO-FLOOR (2-4-1) EXPOSURE 1.
- LAY PANELS IN A STAGGERED PATTERN.
- BLOCK ALL EDGES W/ 2-2x4 BLOCKING.
- GLUE & NAIL TO FRAMING MEMBERS AS FOLLOWS:
  - GLUE SHALL CONFORM TO APA SPECIFICATION AF6-01, APPLIED IN A CONTINUOUS BEAD & IN ACCORDANCE WITH THE MANUFACTURER'S RECOMMENDATIONS.
  - ALL NAILS SHALL BE 8d RING OR SCREW SHANK. NAIL SPACING SHALL BE 4" O.C. @ PANEL EDGES & 12" O.C. @ INTERMEDIATE SUPPORTS.

**CONNECTORS**

- CONNECTORS SHALL BE AS MANUFACTURED BY SIMPSON STRONG-TIE COMPANY, INC., DUBLIN, CA. OR APPROVED EQUAL. NAIL ALL NAIL HOLES.
- CONNECTORS SHALL BE THE MANUFACTURER-DESIGNATED SIZE FOR FRAMED MEMBERS, AND SHALL BE INSTALLED IN STRICT CONFORMANCE WITH MANUFACTURER'S INSTRUCTIONS.
- ALL NAIL & BOLT HOLES SHALL BE ENGAGED, WITH MANUFACTURER-DESIGNATED FASTENERS.
- CONNECTORS SHALL BE INSTALLED AT THE ENDS OF ALL JOISTS & BEAMS FRAMING INTO OTHER (SUPPORTING) MEMBERS (UNLESS OTHERWISE NOTED).
- THE FOLLOWING CONNECTORS SHALL BE PROVIDED AND SHALL BE CONSIDERED THE MINIMUM:
  - SAWN-LUMBER JOISTS — U SERIES
  - I-JOISTS — IUS SERIES
  - MULTIPLE-JOIST/BEAMS — HUS SERIES
  - PSL & LVL BEAMS — LBV SERIES
  - LSL (GLU-LAM) BEAMS — H0US SERIES

**FASTENERS**

- BOLTS**
  - USE ASTM A-307 BOLTS, WITH STANDARD WASHERS AT ALL CONTACT SURFACES.
  - PROVIDE 1/2" x 0'-10" LONG ANCHOR BOLTS @ 3'-0" O.C. AT ALL EXTERIOR WALL SILL PLATES, WITH 2" PROJECTION AND 1" THREAD.
  - ALL BOLTS, NUTS, AND WASHERS EXPOSED TO WEATHER SHALL BE GALVANIZED.
  - ALL BOLTS, NUTS, AND WASHERS IN CONTACT W/ TREATED WOOD SHALL BE GALVANIZED.
- ADHESIVE ANCHORS**
  - USE HILTI HIT RESOQ ANCHORS, OR APPROVED EQUAL.
  - INSTALL IN STRICT ACCORDANCE W/ MANUFACTURER'S RECOMMENDATIONS.
- POWDER-ACTUATED PINS**
  - USE HILTI X-EDM (0.145" SHANK) OR APPROVED EQUAL.
  - INSTALL IN STRICT ACCORDANCE W/ MANUFACTURER'S RECOMMENDATIONS.

**HURRICANE CLIPS:**

ALL HURRICANE CLIP AND NAILS IN CONTACT WITH PRESSURE TREATED WOOD MEMBER SHALL BE GALVANIZED.

**MISCELLANEOUS:**

ALL WOOD IN CONTACT WITH CONCRETE OR MASONRY SHALL BE TREATED LUMBER.

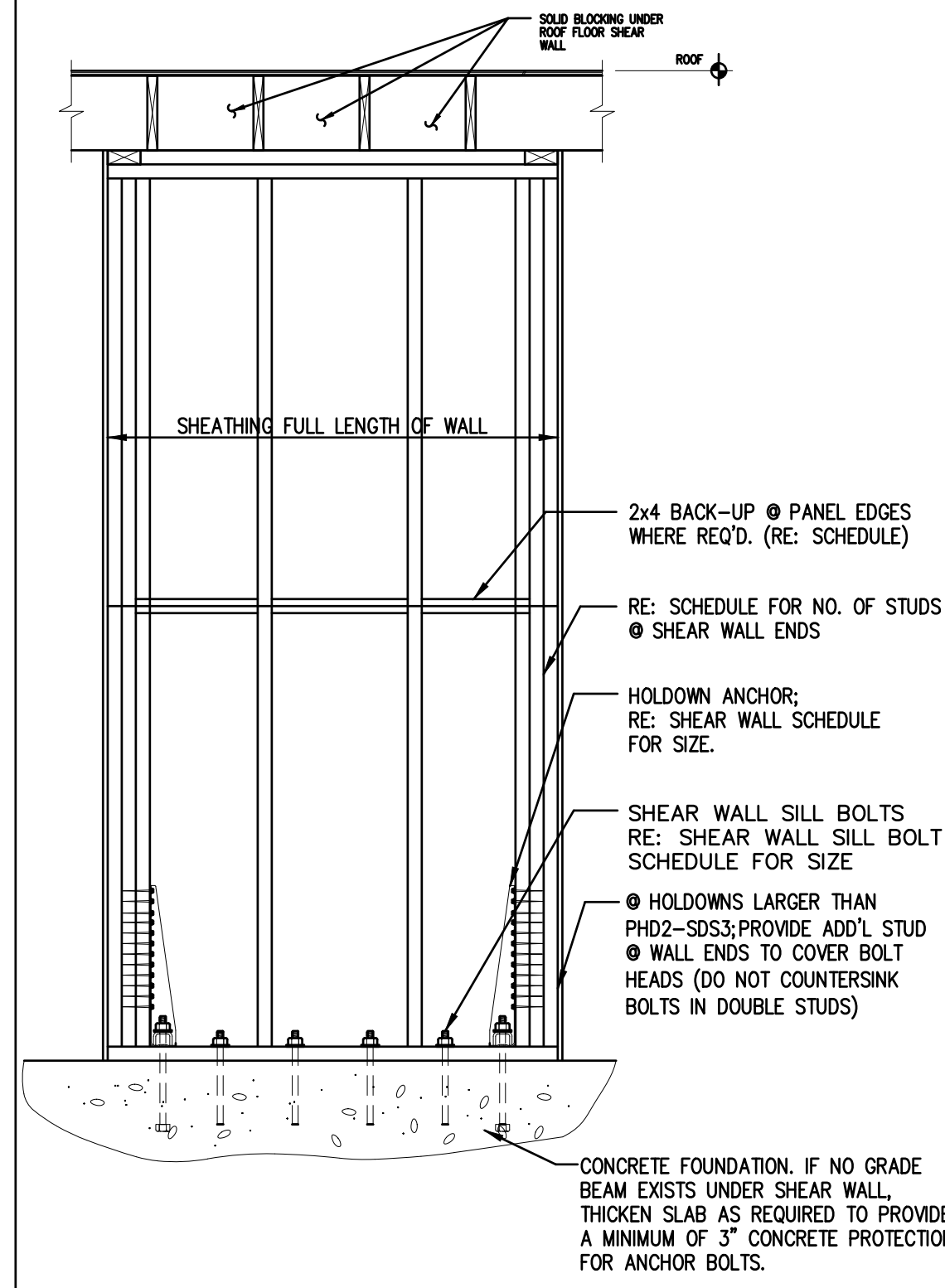

MARK	SHEATHING MATERIAL	BLOCKING	NAILING PATTERN	STUD POST EACH END	HOLD-DOWN MARK	HOLD-DOWN BOLT #
PA	3/8" PLYWOOD C-C	YES	8D COMMON @ 6"	2-2x4	PHD2-SDS3	3/8"
PA	3/8" PLYWOOD C-C	YES	8D COMMON @ 4"	2-2x4	PHD2-SDS3	3/8"
PA	1/2" PLYWOOD C-C	YES	10D COMMON @ 4"	2-2x4	PHD5-SDS3	3/8"
PA	1/2" PLYWOOD C-C	YES	10D COMMON @ 3"	2-2x4	PHD6-SDS3	3/8"
PA	5/8" PLYWOOD C-C	YES	10D COMMON @ 2"	3-2x4	HD08-SDS3	3/8"
GA	1/2" GYPBOARD	NO	5D COOLER @ 7"	2-2x4	PHD2-SDS3	3/8"
GA	1/2" GYPBOARD	YES	5D COOLER @ 4"	2-2x4	PHD2-SDS3	3/8"
GA	5/8" GYPBOARD	YES	6D COOLER @ 4"	2-2x4	PHD2-SDS3	3/8"

MARK	SILL PLATE BOLTING FOR SHEAR WALL	MIN. EMBEDMENT
PA	1/2" @ 2'-6" O.C.	6"
PA	1/2" @ 2'-0" O.C.	6"
PA	3/8" @ 2'-0" O.C.	6"
PA	3/8" @ 1'-6" O.C.	6"
PA	3/8" @ 1'-0" O.C.	6"

- SHEAR WALL NOTES:**
- WHERE "BLOCKING" IS INDICATED, PROVIDE 2x4 BACK-UP AT ALL GYPBOARD OR PLYWOOD PANEL EDGES.
  - NAILING PATTERN APPLIES AT ALL PANEL EDGES. AT INTERMEDIATE SUPPORTS, PROVIDE NAILING @ 12" O.C. USING CORRESPONDING NAIL SIZE.
  - SHEATHING MATERIAL AND NAILING PATTERN APPLY TO ONE SIDE OF SHEAR WALL ONLY. WHERE A SHEAR WALL IS CALLED OUT ON A PLAN, PROVIDE SCHEDULED SHEATHING MATERIAL AND NAILING FOR THE FULL LENGTH OF THAT WALL.
  - PROVIDE SCHEDULED STUDS AT EACH END OF SHEAR WALL OR SEGMENT THEREOF.
  - HOLD-DOWN CONNECTORS:
    - CONNECTORS SHALL BE AS MANUFACTURED BY SIMPSON STRONG-TIE COMPANY, INC., SAN LEANDRO, CA OR APPROVED EQUAL.
    - THE FOLLOWING SUBSTITUTIONS MAY BE MADE:
- | HOLD-DOWN MARK | SUBSTITUTION           |                 |
|----------------|------------------------|-----------------|
|                | @ SLAB / FOUNDATION    | @ FLOOR FRAMING |
| PHD2-SDS 3     | HD2A OR STD10 OR HTT16 | HST2 OR MSTC40  |
| PHD5-SDS 3     | HD5A OR STD14 OR HTT22 | HST3 OR MSTC52  |
| PHD6-SDS 3     | HD6A OR HTT22          | HST3 OR MSTC66  |
- ALL HOLD-DOWNS MUST BE INSTALLED IN STRICT ADHERENCE TO MANUFACTURER'S INSTRUCTIONS, USING BOLT & NAIL NUMBERS, SIZES & LENGTHS AS SPECIFIED BY MANUFACTURER.
  - WHERE PLYWOOD IS SHOWN ON BOTH FACES OF A SHEAR WALL:
    - DOUBLE STUDS OR 3" WIDE STUDS MUST BE USED.
    - STAGGER PLYWOOD JOINTS AT WALL FACES.
    - USE 4x4 WOOD POSTS @ EA. END TO BOLT HOLD-DOWNS.
    - PROVIDE DOUBLE 2x SILL PLATE W/ 1/2" ANCHOR BOLTS @ 24" c. IN ADDITION TO HOLD-DOWN ANCHOR BOLTS.
  - SIMPSON "WEDGE-ALL" WEDGE ANCHORS MAY BE USED IN LIEU OF SCHEDULED ANCHOR BOLTS TO MATCH (DIAMETERS). MINIMUM EMBEDMENT LENGTHS AS SUGGESTED BY MANUFACTURER.
  - BOLTS SPECIFIED FOR THIS TABLE MUST BE A490 RATED BOLTS

TYPICAL SHEAR WALL DETAILS

DECK TYPE & THICKNESS	NAIL SIZE	NUMBER OR NAILING PATTERN
PLYWOOD OR PARTICLE BOARD		
1/2" OR LESS	8D COMMON OR EQUAL	6" O.C. @ PANEL EDGES
19/32" THRU 3/4"	8D COMMON OR EQUAL	10" O.C. @ INTERMEDIATE SUPPORTS TYPICAL (TYPICAL)
7/8" THRU 1" (FLR.)	8D COMMON OR EQUAL	
1 1/8" THRU 1 1/4" (FLR.)	10D COMMON OR EQUAL	

CONNECTED MEMBERS	NAIL SIZE	NUMBER OR NAILING PATTERN
BRIDGING TO JOIST	8D COMMON	2 TOE NAIL EA. END
SOLE PLATE TO JOIST OR BLOCKING	16D COMMON	@ 16" O.C. FACENAIL
TOP PLATE TO STUD	16D COMMON	2 END NAIL
STUD TO SOLE PLATE	8D COMMON OR 16D COMMON	4 TOE NAIL OR 2 END NAIL
DOUBLE STUDS	16D COMMON	@ 24" FACE NAIL
DOUBLED TOP PLATES	16D COMMON	@ 16" FACE NAIL
TOP PLATES: LAPS & INTERSECTIONS	16D COMMON	2 FACE NAIL
CONTINUOUS HEADER, TWO PIECE	16D COMMON	@ 16" FACE NAIL ALONG EA. EDGE
CEILING JOISTS TO PLATE	8D COMMON	3 TOE NAIL
CONTINUOUS HEADER TO STUD	8D COMMON	4 TOE NAIL
CEILING JOISTS, LAPS OVER PARTITIONS	16D COMMON	3 FACE NAIL
CEILING JOISTS TO PARALLEL RAFTERS	16D COMMON	3 FACE NAIL
RAFTER TO PLATE	8D COMMON	3 TOE NAIL
1" BRACE TO EACH STUD & PLATE	8D COMMON	2 FACE NAIL
BUILT UP CORNER STUDS	16D COMMON	@ 24" FACE NAIL
CONTINUOUS HEADER, 3 OR MORE PIECE & BUILT UP ORDERS OR BEAMS	BOLTS	RE: GEN. NOTES.

SHEATHING TYPE & THICKNESS	FASTNER SIZE & TYPE	NAILING PATTERN
PLYWOOD & PARTICLE BOARD		
LESS THAN 1/2"	6D COMMON OR EQUAL	6" O.C. @ PANEL EDGES
1/2" THRU 3/4"	8D COMMON OR EQUAL	10" O.C. @ INTERMEDIATE SUPPORTS
FIBERBOARD		
1/2" OR LESS	6D COMMON OR EQUAL	6" O.C. @ INTERMEDIATE SUPPORTS
25/32"	8D COMMON OR EQUAL	
GYP-SUM SHEATHING		
1/2" OR 5/8"	12 GA. (4) OR EQUAL	4" O.C. @ EDGES 6" O.C. @ INTERMEDIATE SUPPORTS
GYP-SUM WALLBOARD		
1/2"	1 3/8" DRYWALL NAILS	7" O.C. @ CEILINGS
5/8"	1 1/2" DRYWALL NAILS	8" O.C. @ WALLS
PANEL SIDING (TO FRAMING)		
1/2" OR LESS	6D COMMON OR EQUAL	1 EACH PANEL
5/8"	8D COMMON OR EQUAL	

- NOTES ON "NAILING--WALL SHEATHING & SIDING"**
- CORROSION-RESISTANT SIDING OR CASING NAILS CONFORMING TO THE REQUIREMENTS OF IRC
  - CORROSION-RESISTANT ROOFING NAILS WITH 7/16-INCH DIAMETER HEAD AND 1 1/2-INCH IN LENGTH FOR 1/2-INCH SHEATHING AND 1 3/4-INCH LENGTH FOR 25/32-INCH SHEATHING CONFORMING TO THE REQUIREMENTS OF IRC
  - CORROSION-RESISTANT STAPLES WITH NOMINAL 7/16-INCH CROWN AND 1 1/8-INCH LENGTH FOR 1/2-INCH SHEATHING AND 1 1/2-INCH LENGTH FOR 25/32-INCH SHEATHING CONFORMING TO THE REQUIREMENTS OF IRC
  - CORROSION-RESISTANT, LARGE HEAD.

TYPICAL NAILING SCHEDULE

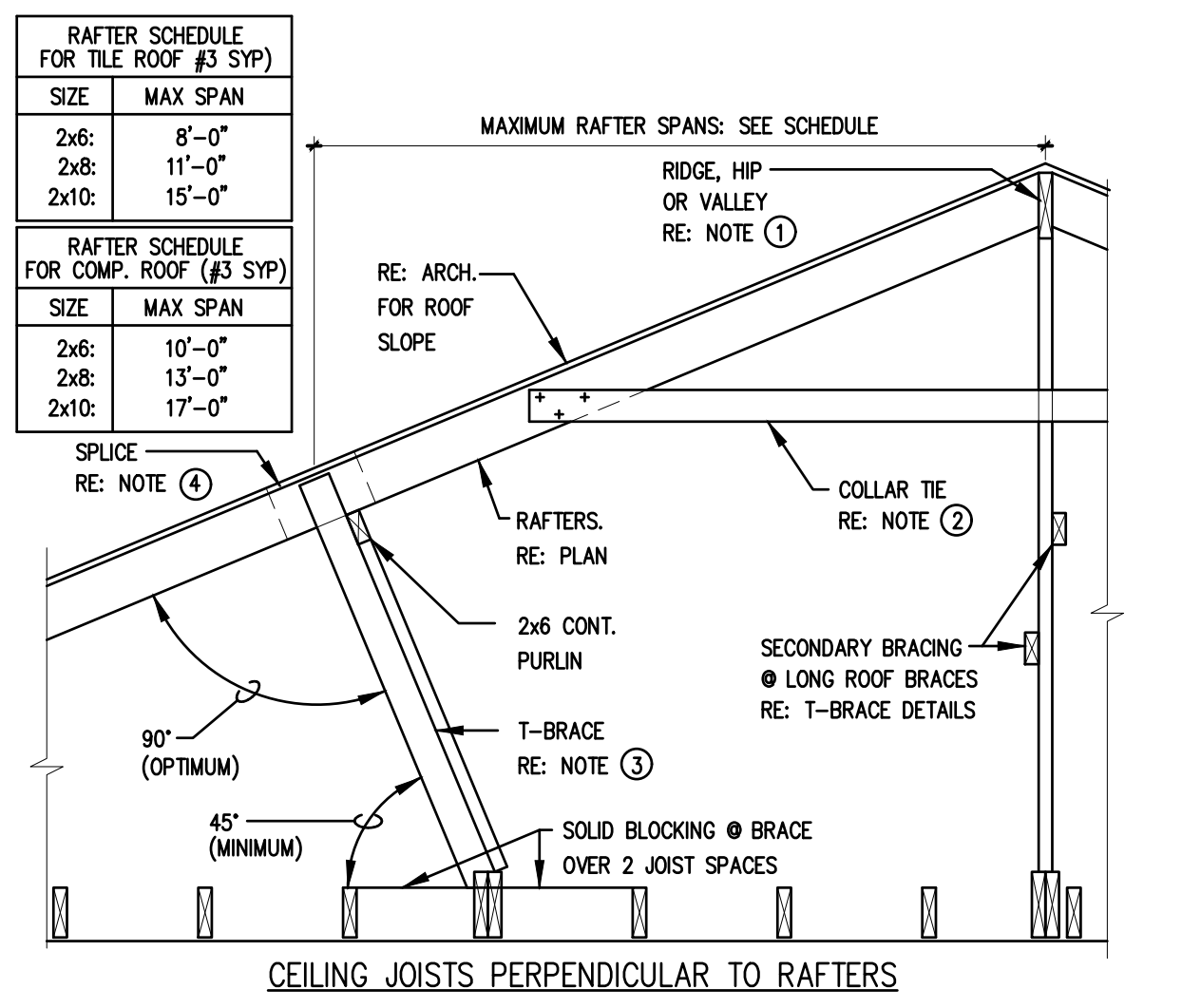
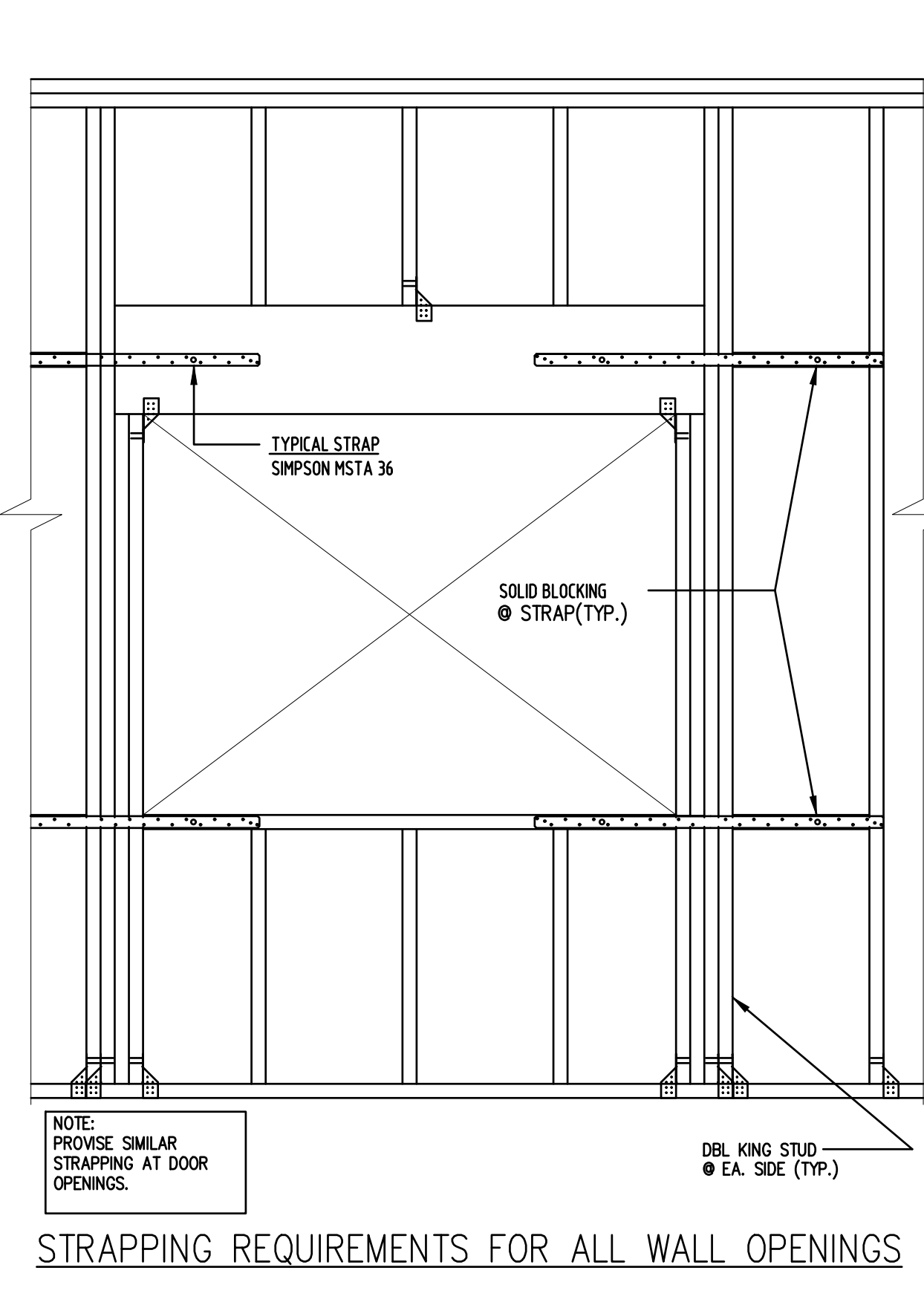

- DETAIL KEYED NOTES**
- RIDGE BEAM, HIP RAFTER, OR VALLEY RAFTER**  
 DEPTH SHALL BE THE LARGER OF THE FOLLOWING:  
 A. ONE SIZE DEEPER THAN THE LARGEST RAFTER FRAMING INTO IT (2 x LUMBER)  
 B. DEPTH OF CUT END OF RAFTER.
  - COLLAR TIES**  
 2x6; LOCATED @ UPPER ONE THIRD (1/3) OF ROOF @ EVERY OTHER RAFTER
  - T-BRACE**  
 A. RE: TYPICAL DETAILS BELOW  
 B. MAXIMUM SPACING AS FOLLOWS:  
 4'-0" @ 2x6 CONT. PURLIN  
 5'-0" @ RIDGE BEAM, HIP OR VALLEY RAFTER  
 C. BRACE SHALL BEAR ON AN INTERIOR WALL, BEAM OR STRONG-BACK (DOUBLE, 2 SIZES LARGER THAN JOIST) RE: FRAMING PLAN.
  - RAFTER & RIDGE SPLICES**  
 A. LOCATE SPLICE OVER A PURLIN, OR PROVIDE ADDITIONAL BRACE @ SPLICE  
 B. MINIMUM LAP = 12" NAIL W/ 6-16 d NAILS.

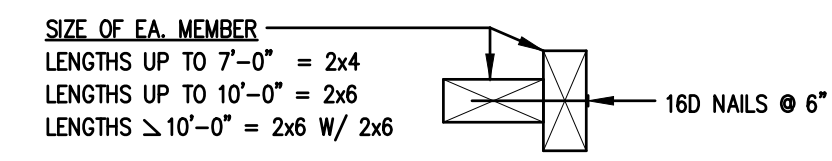

TYPICAL ROOF BRACING DETAILS

**GENERAL NOTES**

**OPTIMUM PERSONAL CARE PH.2**

1110 LAKEVIEW DRIVE  
 SUGAR LAND, TX. 77478

**ISSUE HISTORY**

DATE	ISSUED FOR
	CLIENT REVIEW
	PERMIT
	CONSTRUCTION

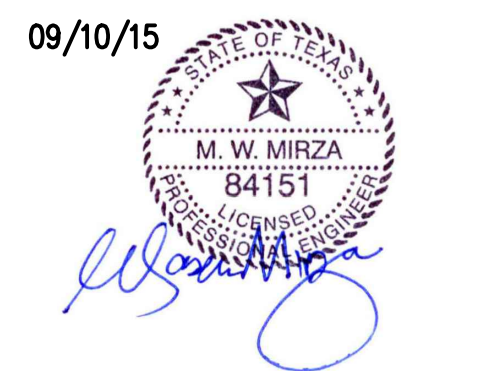

**PARAMOUNT ENGINEERING LLC**

BUILDINGS BRIDGES INSPECTIONS MARINE STRUCTURES CIVIL ENGINEERING & STRUCTURAL ENGINEERING

10145 LONG POINT DR.  
 HOUSTON, TX 77043  
 TEL : (713) 636-9977  
 FAX : (713) 888-9872  
 CEL : (713) 204-1742

TBPE REGISTRATION # F-3394

DRAWN BY: E.V. CHECKED BY: M.M.

PROJ. NO.: PE12-225

SHEET: **S7**

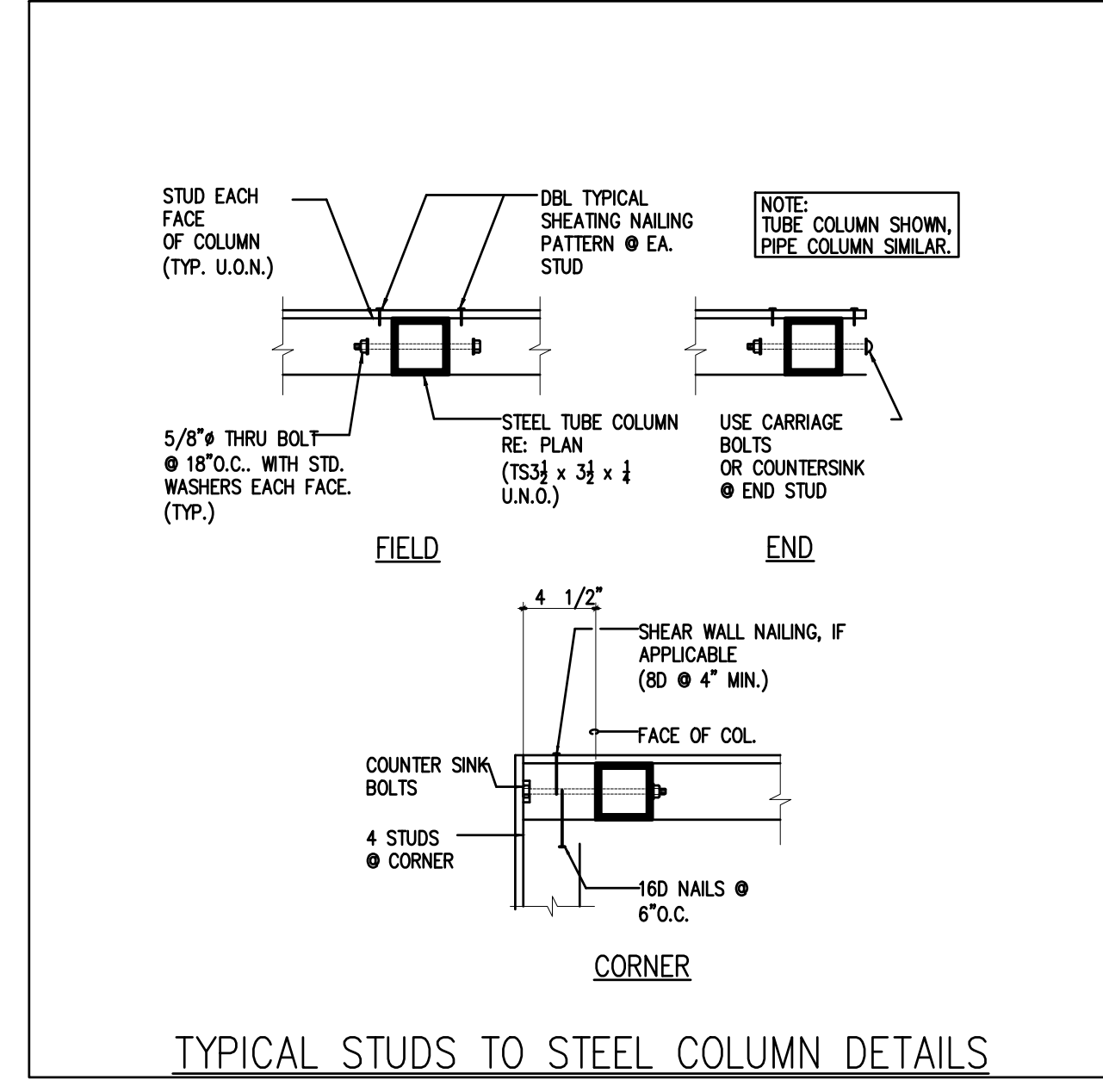
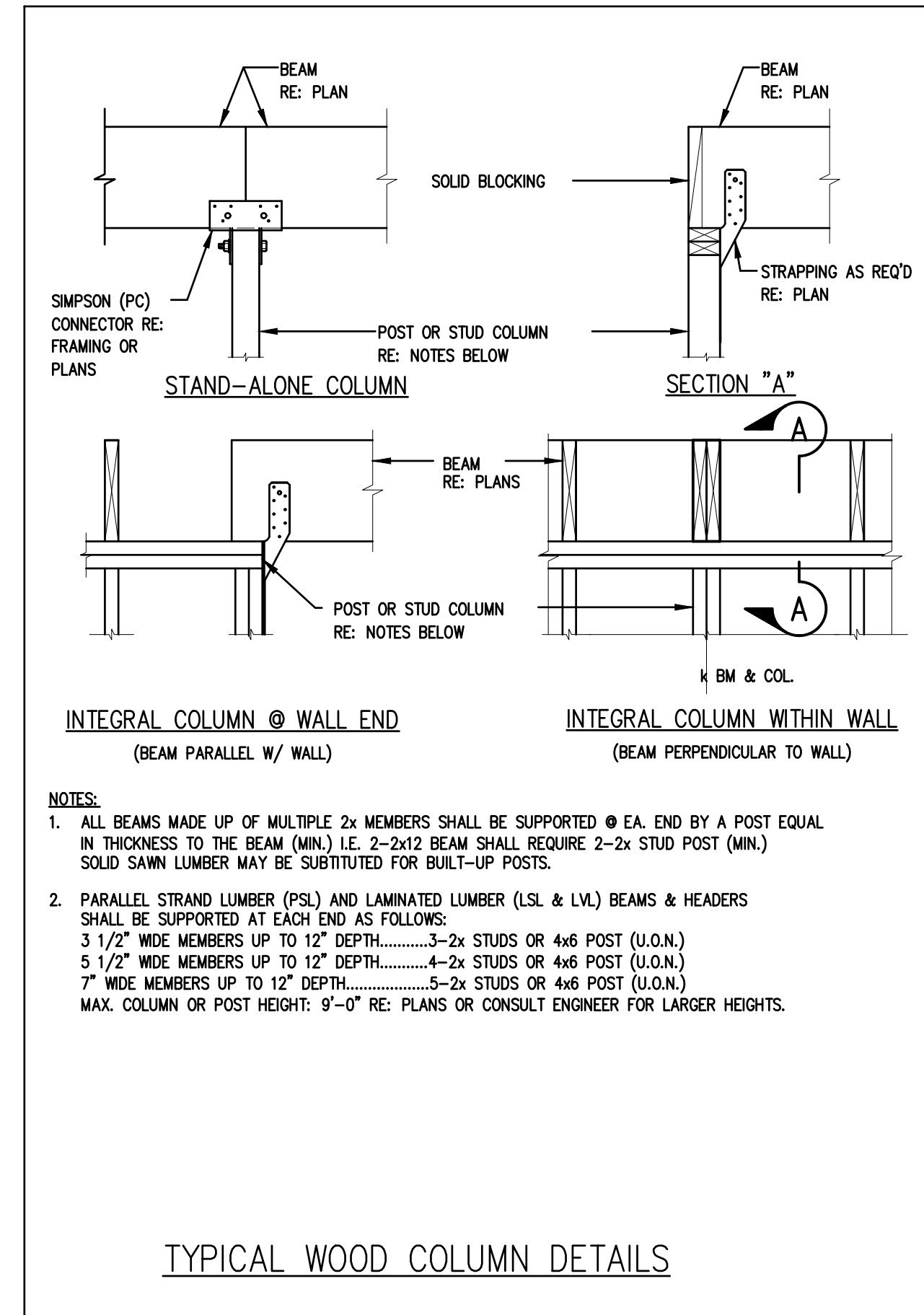
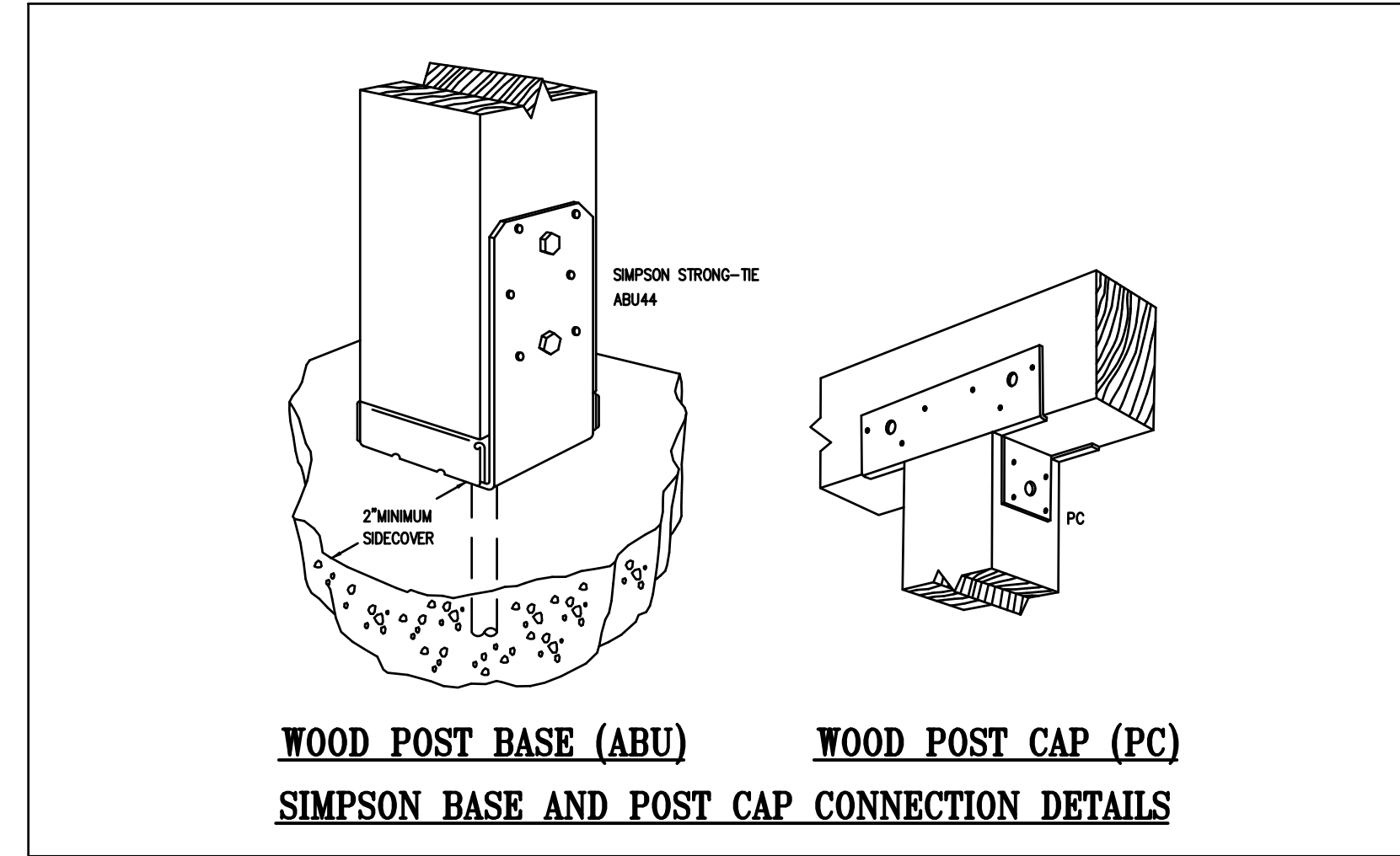
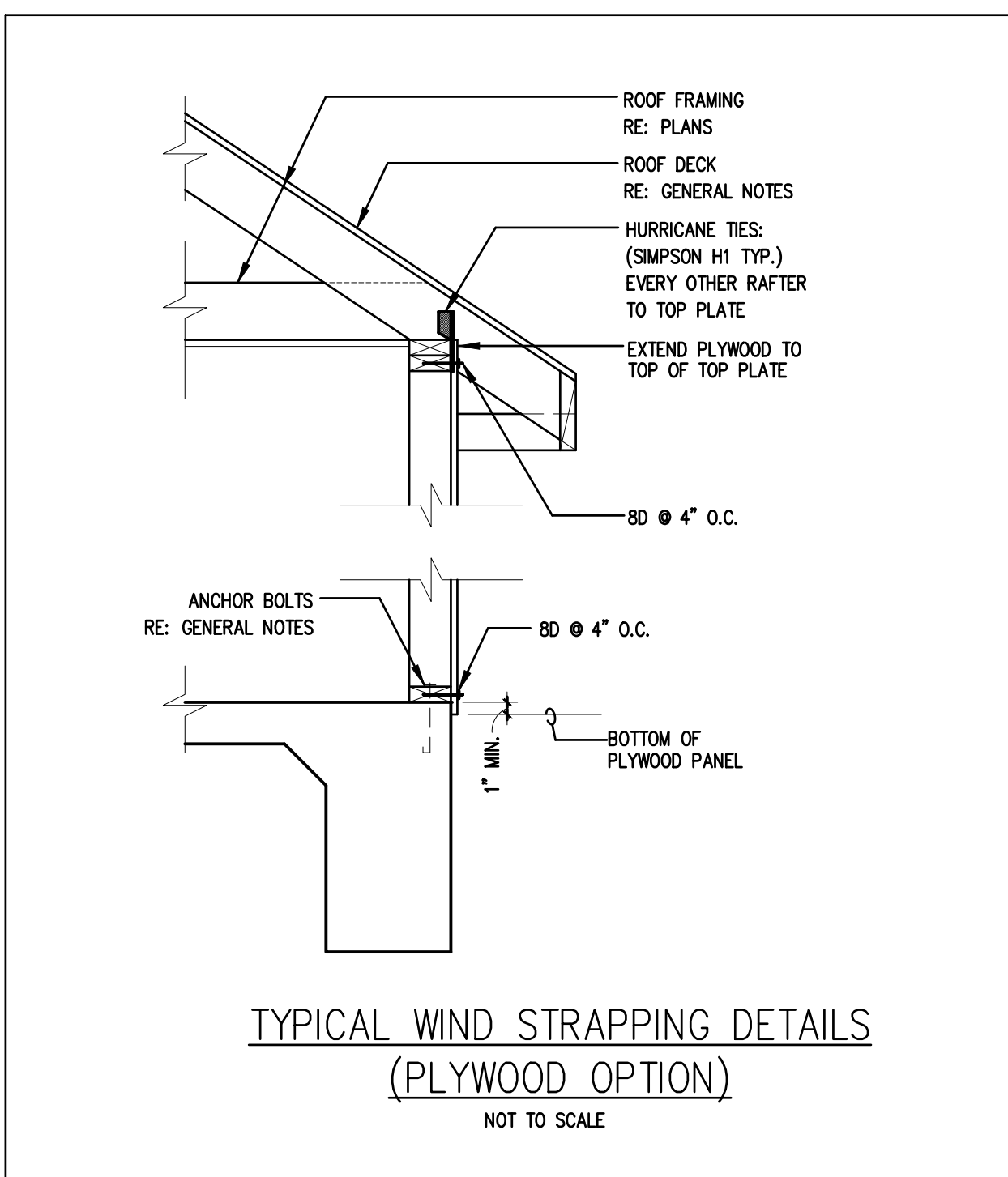
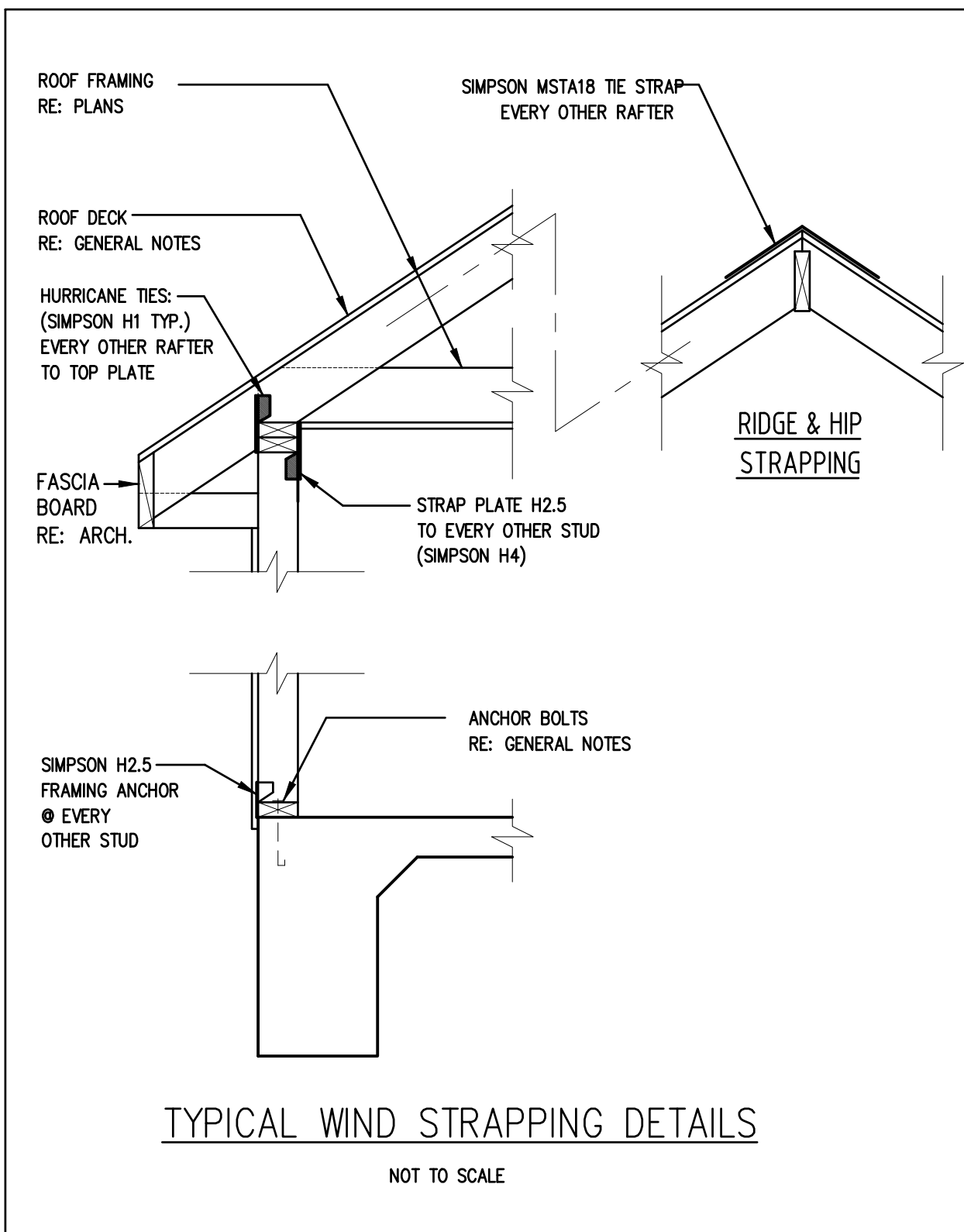

GENERAL NOTES: STRUCTURAL AND MISC. STEEL

- CONFORM TO THE FOLLOWING MATERIAL SPECIFICATIONS:  
STRUCTURAL & MISC. SHAPES: ASTM A-36  
PIPE COLUMNS: ASTM A-53-B  
TUBE COLUMNS: ASTM A-500-B
- ALL DETAILING SHALL BE IN CONFORMANCE WITH THE STANDARDS OF THE AMERICAN INSTITUTE OF STEEL CONSTRUCTION (AISC).
- UNLESS NOTED OTHERWISE, PROVIDE FRAMED BEAM CONNECTIONS IN ACCORDANCE WITH PART 4, AISC MANUAL - 3/4" ASTM A-307 BOLTS. DESIGN FOR SHEARS IN TABLES FOR ALLOWABLE LOADS ON BEAMS, PART 2.
- FIELD CONNECTIONS SHALL BE EQUIVALENT TO STANDARD BOLTED CONNECTIONS USING 3/4" ASTM A-307 BOLTS UNLESS OTHERWISE SHOWN. IF CONNECTION BOLTS ARE IN SINGLE SHEAR, BOLTS SHALL BE PLACED IN TWO VERTICAL ROWS. CONNECTIONS SHALL BE BOLTED OR WELDED - SEE DETAILS.
- WELDING SHALL CONFORM TO THE "CODE FOR WELDING IN BUILDING CONSTRUCTION" BY THE AMERICAN WELDING SOCIETY, LATEST EDITION. WELDS NOT CALLED OUT ON DRAWINGS SHALL BE 1/4" CONTINUOUS FILLET WELDS. WELDING ELECTRODES SHALL CONFORM TO AWS A5.1 OR A5.5 E70XX.
- ALL WELDING SHALL PERFORMED BY CERTIFIED WELDERS.
- ANCHOR BOLTS SHALL CONFORM TO ASTM A-307 FOR HEADED A.B. AND A-36 FOR UNHEADED AND HOOKED A.B., AND SHALL BE SET USING RIGID TEMPLATES.
- PROVIDE TEMPORARY BRACING & SHORING FOR ALL STEEL FRAMING AS REQ'D TO ENSURE STABILITY DURING CONSTRUCTION.  
NOTE THAT STEEL FRAMING MEMBERS MAY NOT BE STABLE DURING CONSTRUCTION UNTIL PERMANENTLY CONNECTED WITHIN THE OVERALL STRUCTURE.
- IT IS THE RESPONSIBILITY OF THE CONTRACTOR TO VERIFY ALL DIMENSION, ELEVATION AND REVIEW THESE DRAWINGS BEFORE FABRICATION OR ORDERING MATERIALS.

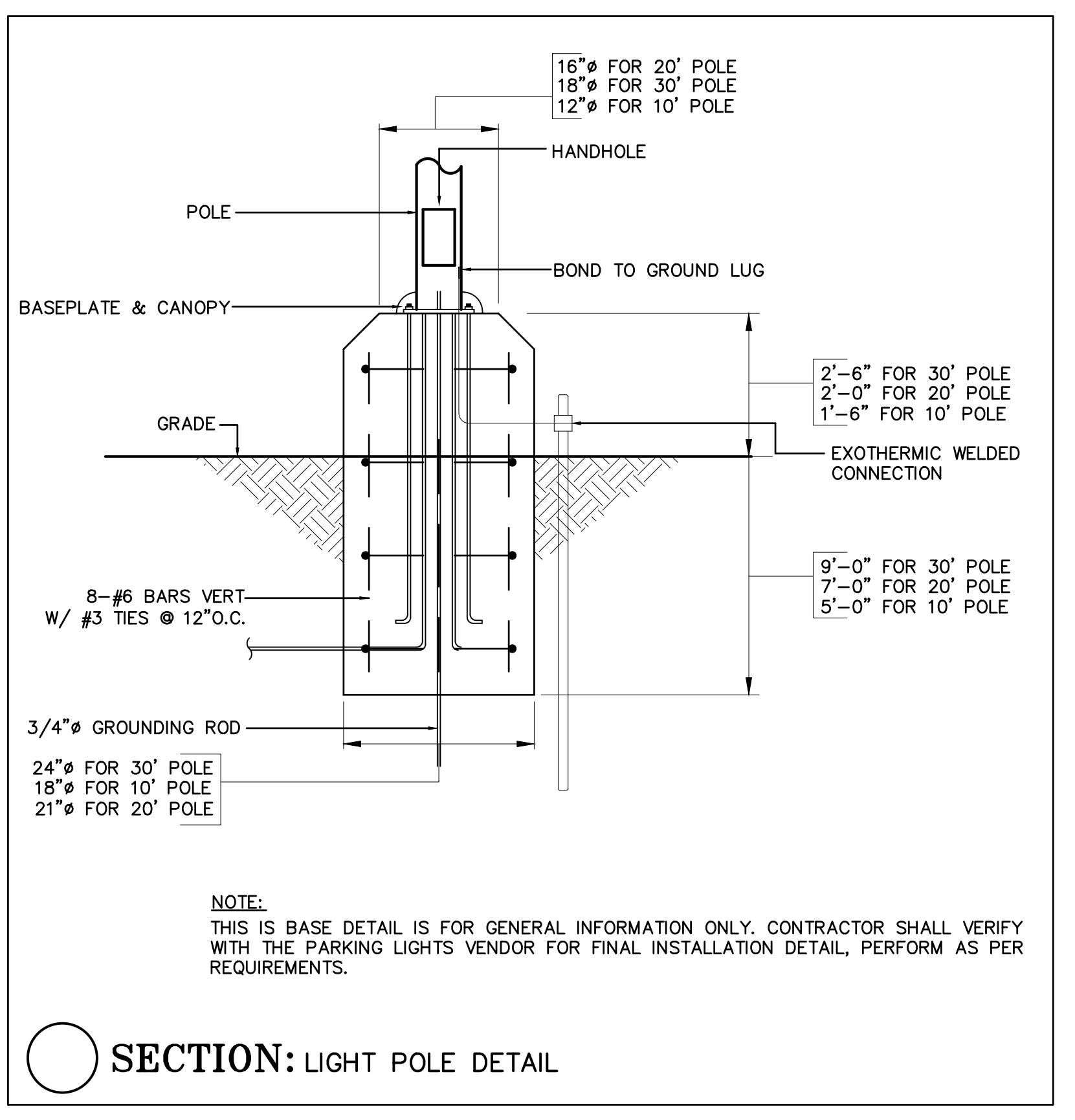
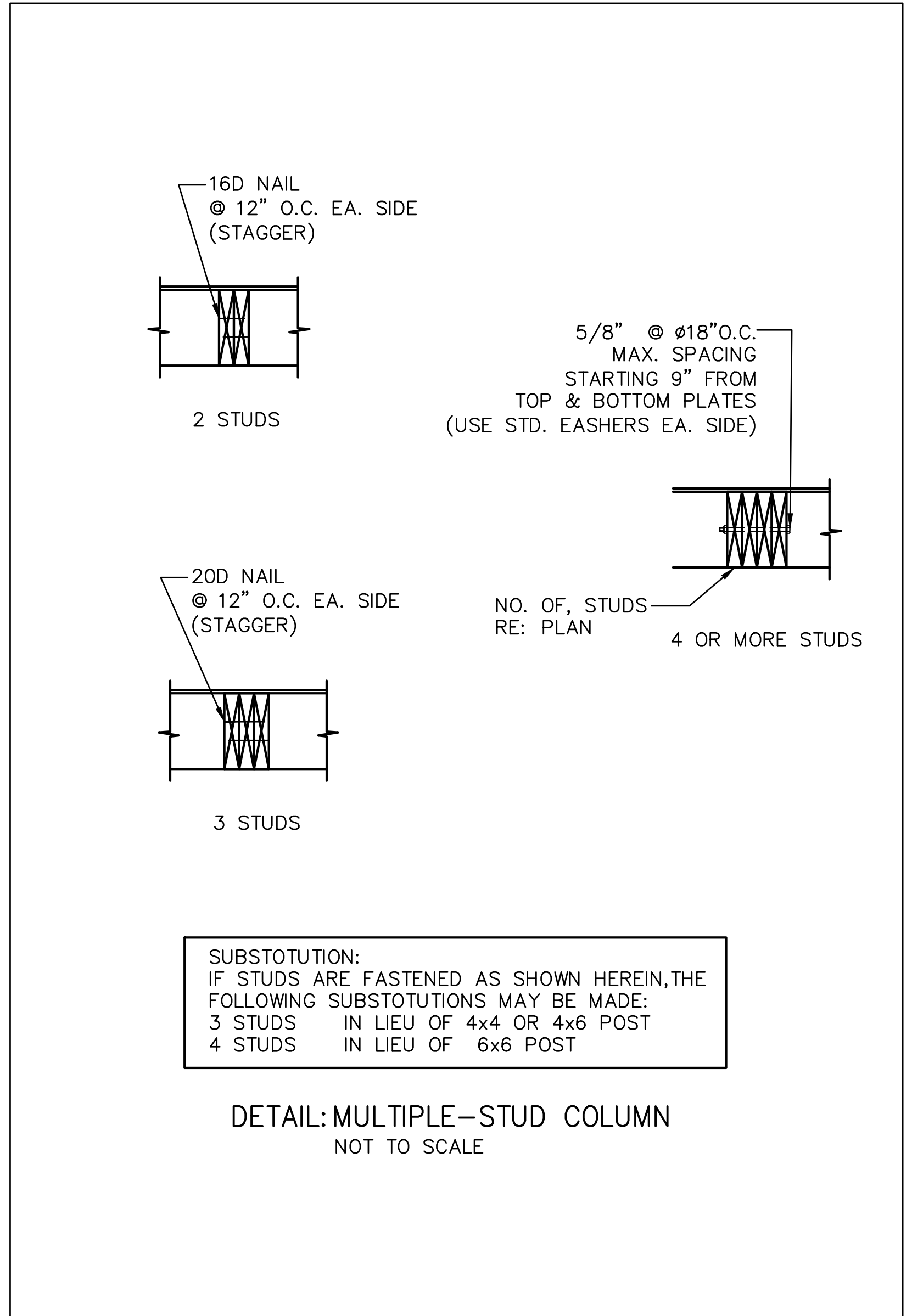
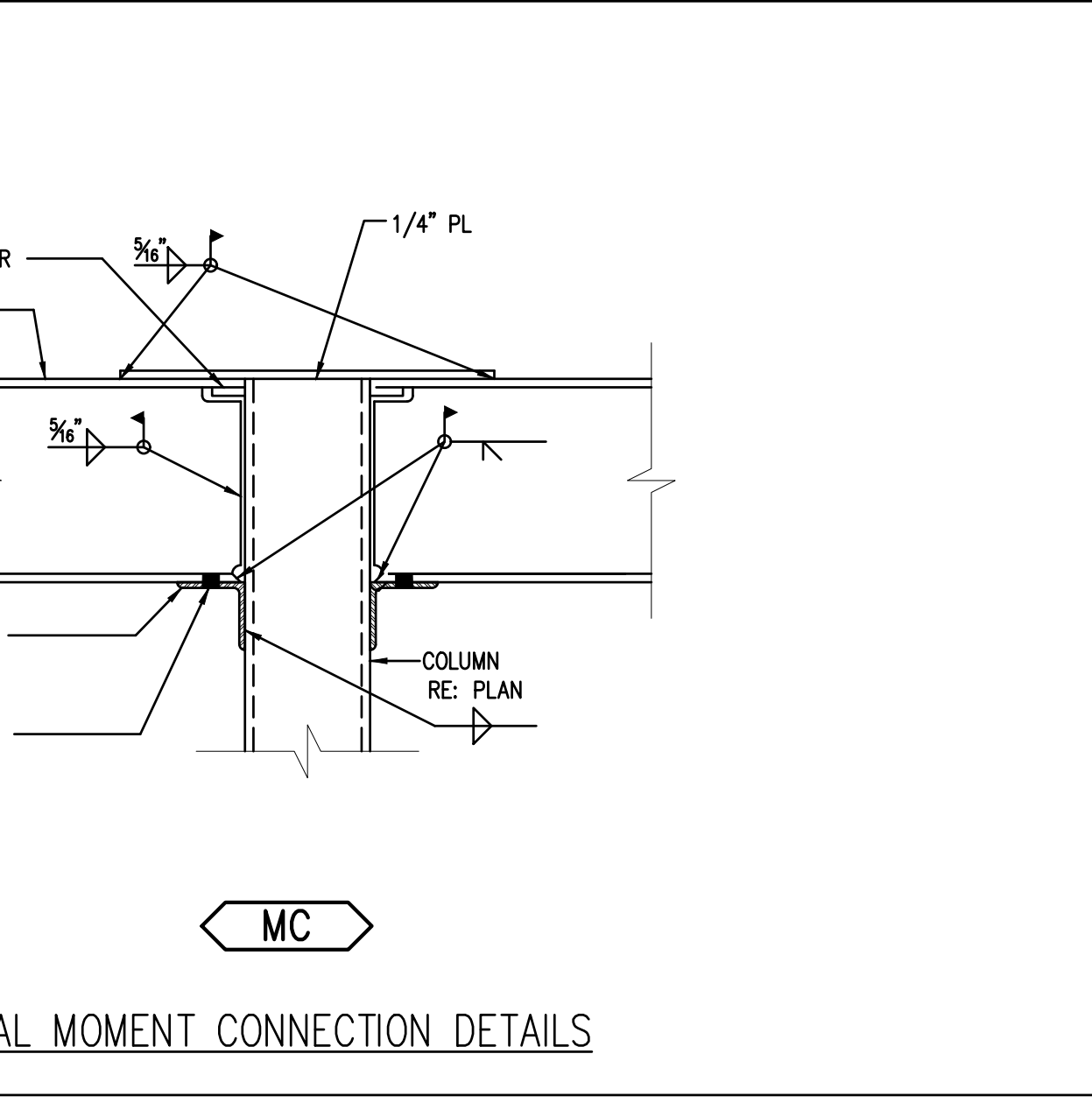
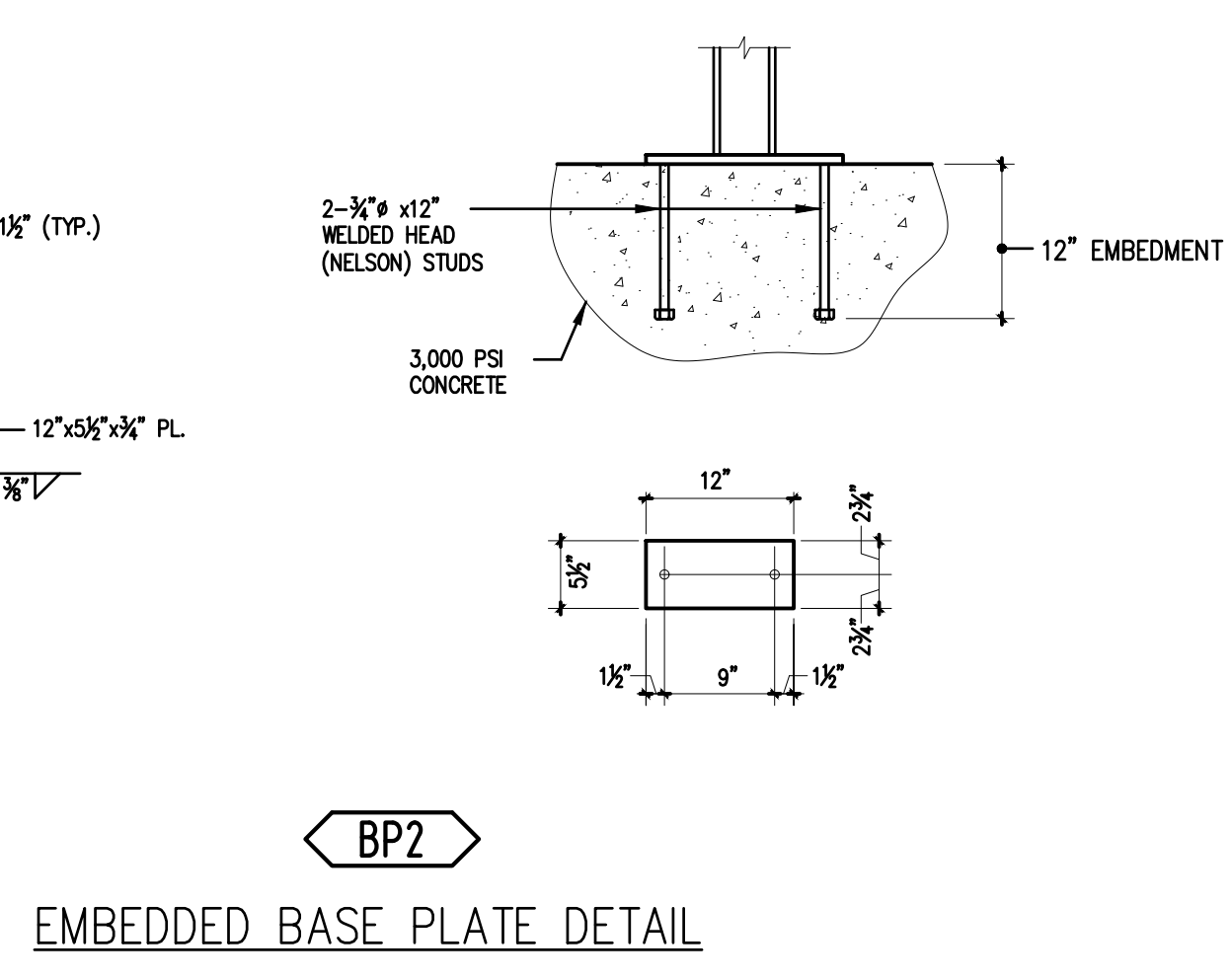
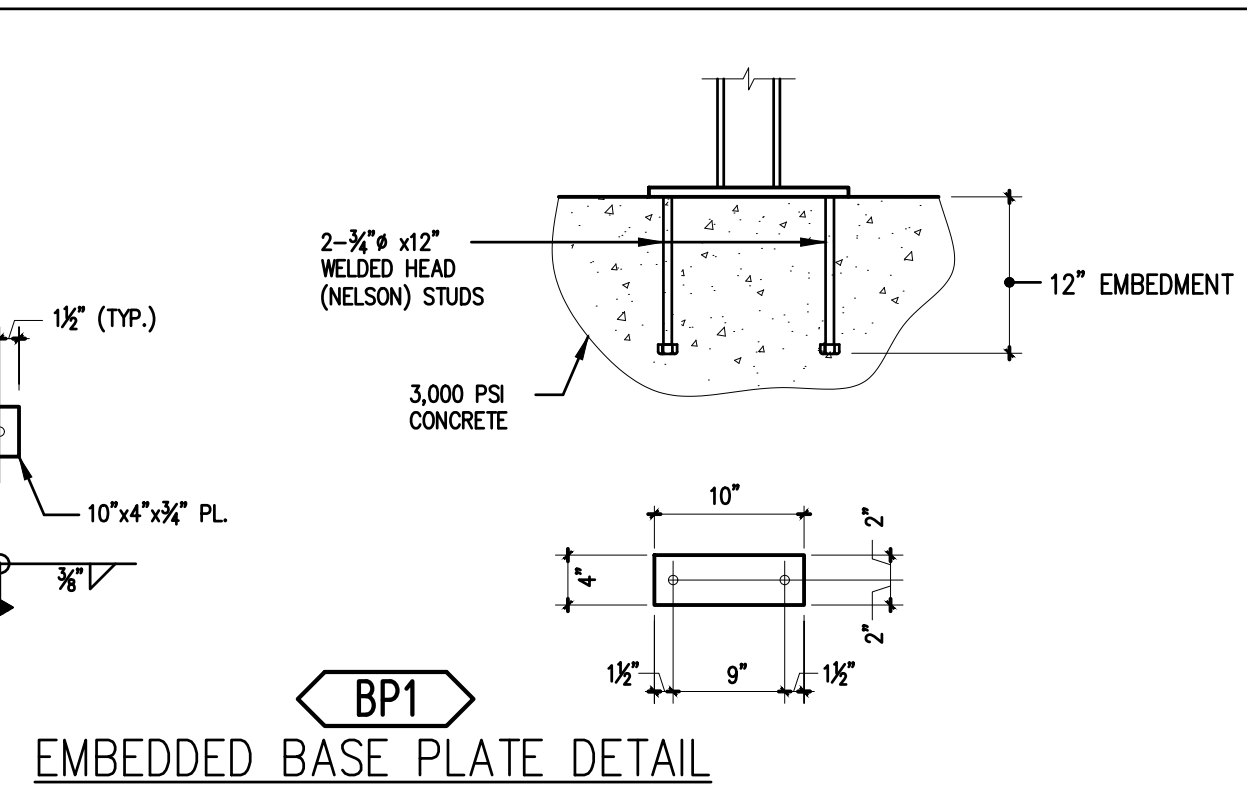

GENERAL NOTES

OPTIMUM PERSONAL CARE PH.2  
1110 LAKEVIEW DRIVE  
SUGAR LAND, TX. 77478

ISSUE HISTORY

DATE	ISSUED FOR
	CLIENT REVIEW
	PERMIT
	CONSTRUCTION

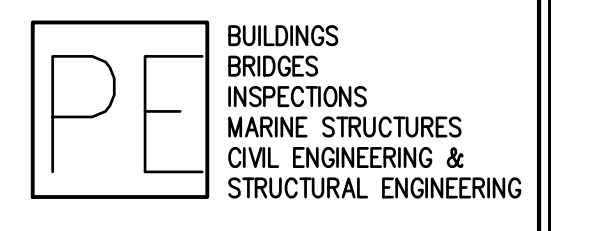
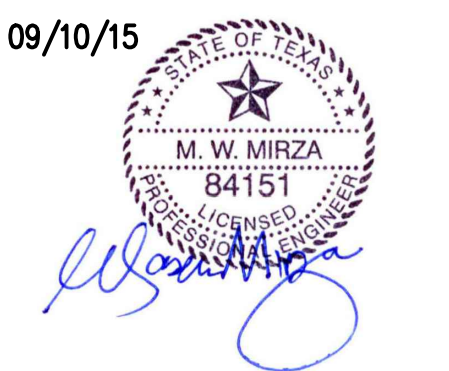

PARAMOUNT ENGINEERING LLC  
BUILDINGS BRIDGES INSPECTIONS MARINE STRUCTURES CIVIL ENGINEERING & STRUCTURAL ENGINEERING

10145 LONG POINT DR. HOUSTON, TX 77043  
TEL : (713) 636-9977  
FAX : (713) 888-9872  
CEL : (713) 204-1742

TBPE REGISTRATION # F-3394

DRAWN BY: E.V. CHECKED BY: M.M.

PROJ. NO.: PE12-225

SHEET: S8

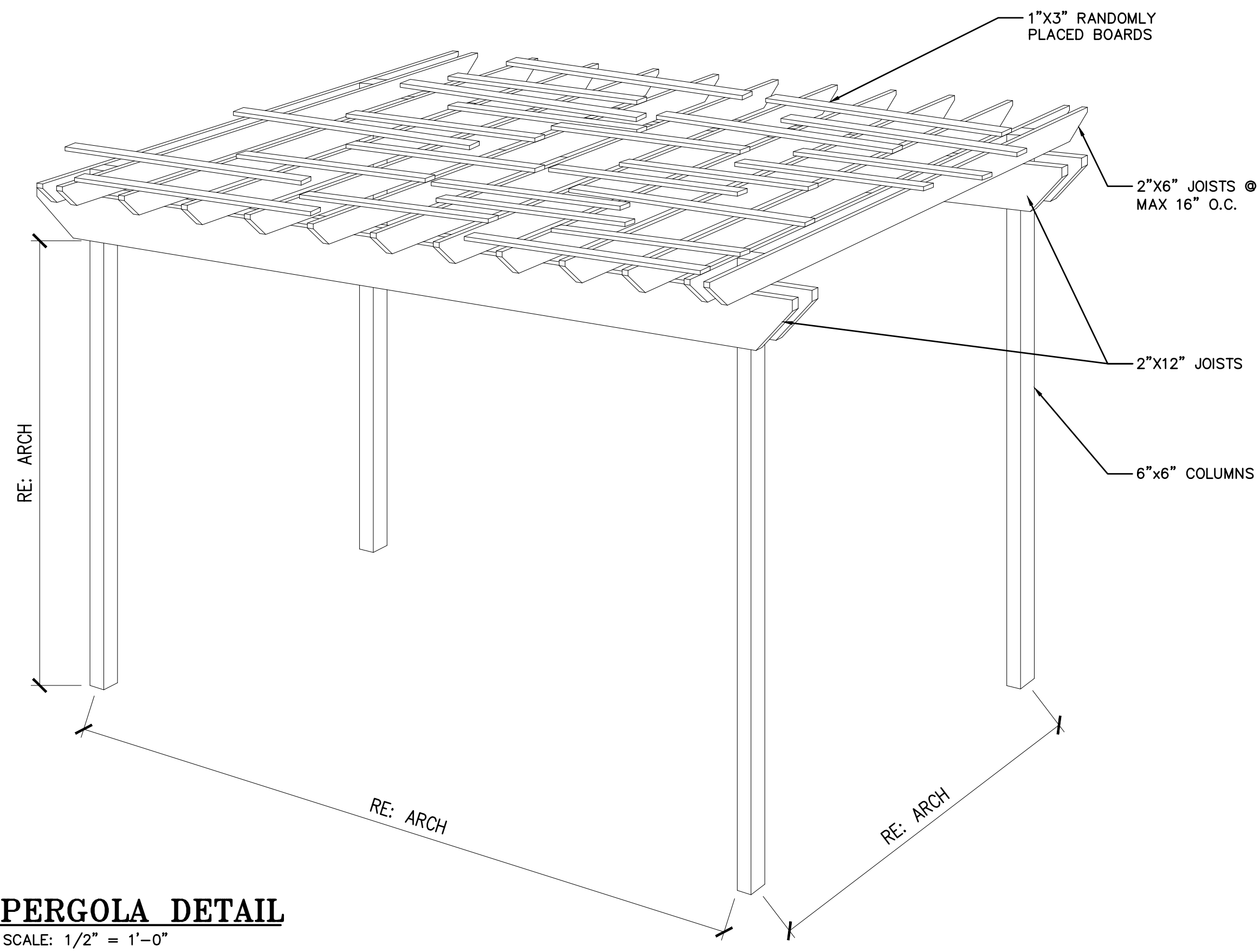

**PERGOLA DETAIL**  
SCALE: 1/2" = 1'-0"

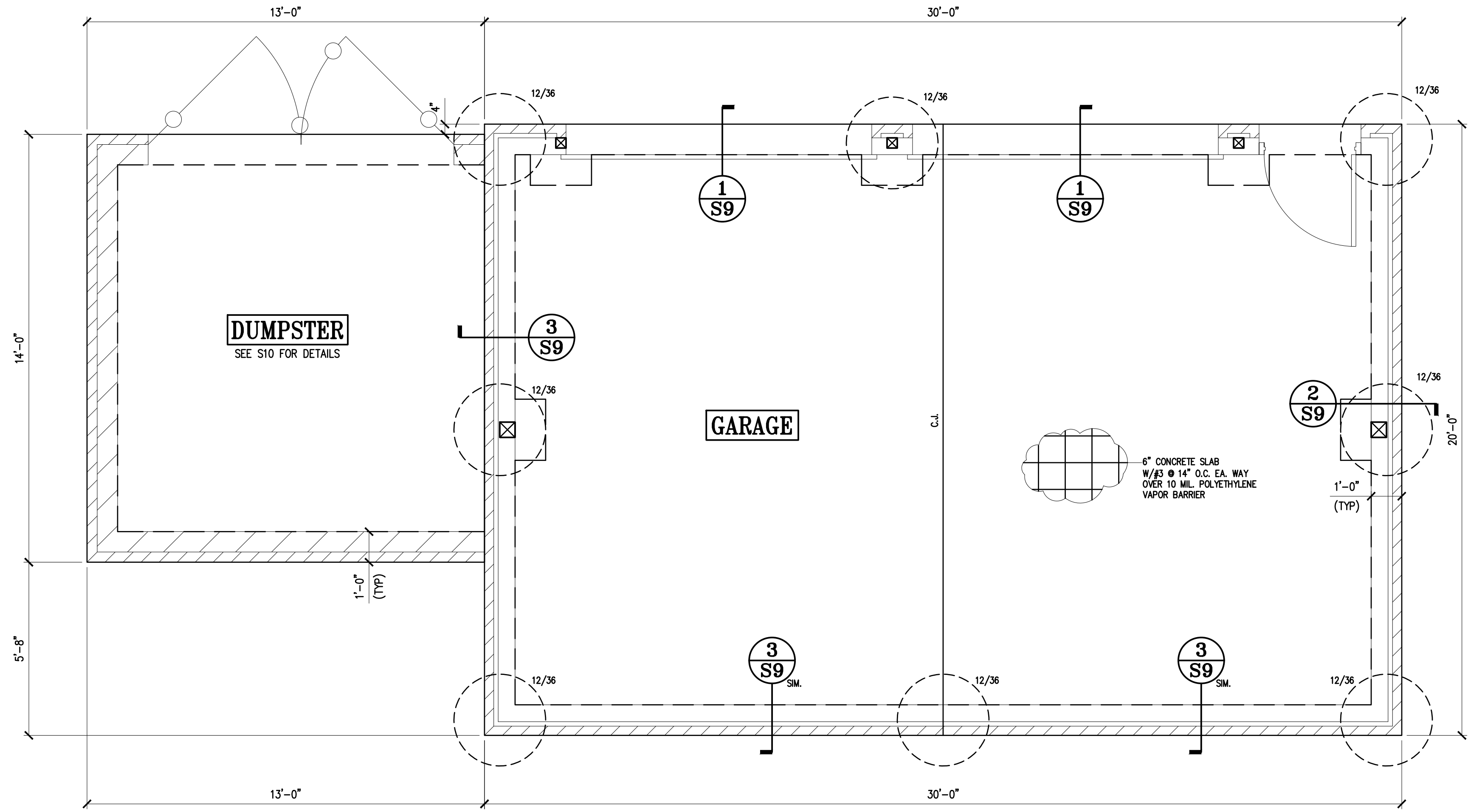

**DUMPSTER GARAGE FOUNDATION PLAN**  
SCALE: 3/8" = 1'-0"

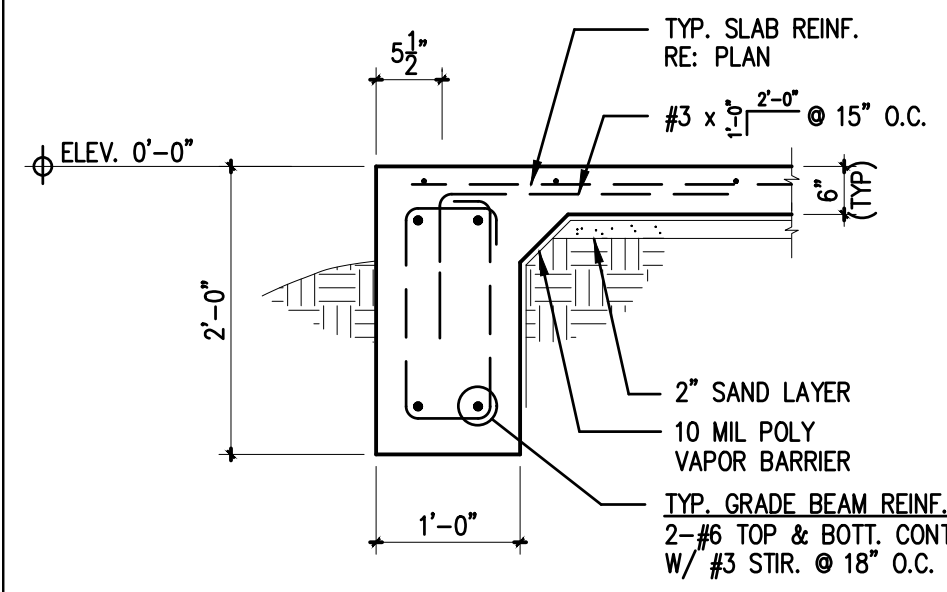

**1 SECTION: TYPICAL GRADE BEAM @ O.H. DOOR**

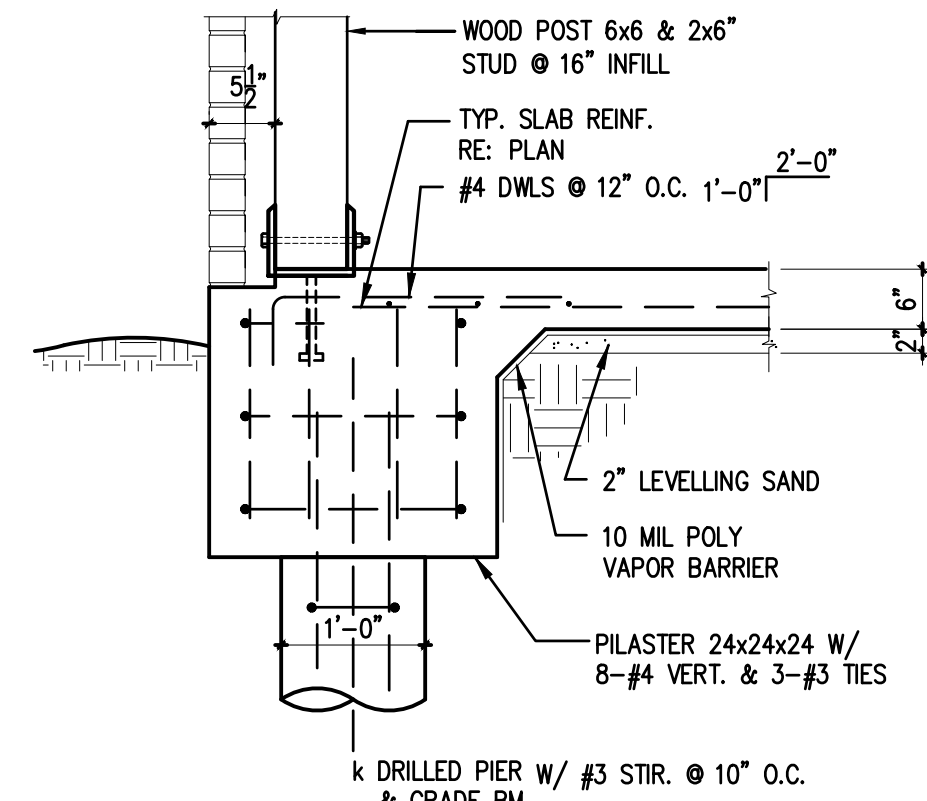

**2 SECTION: AT COLUMN & WALL**

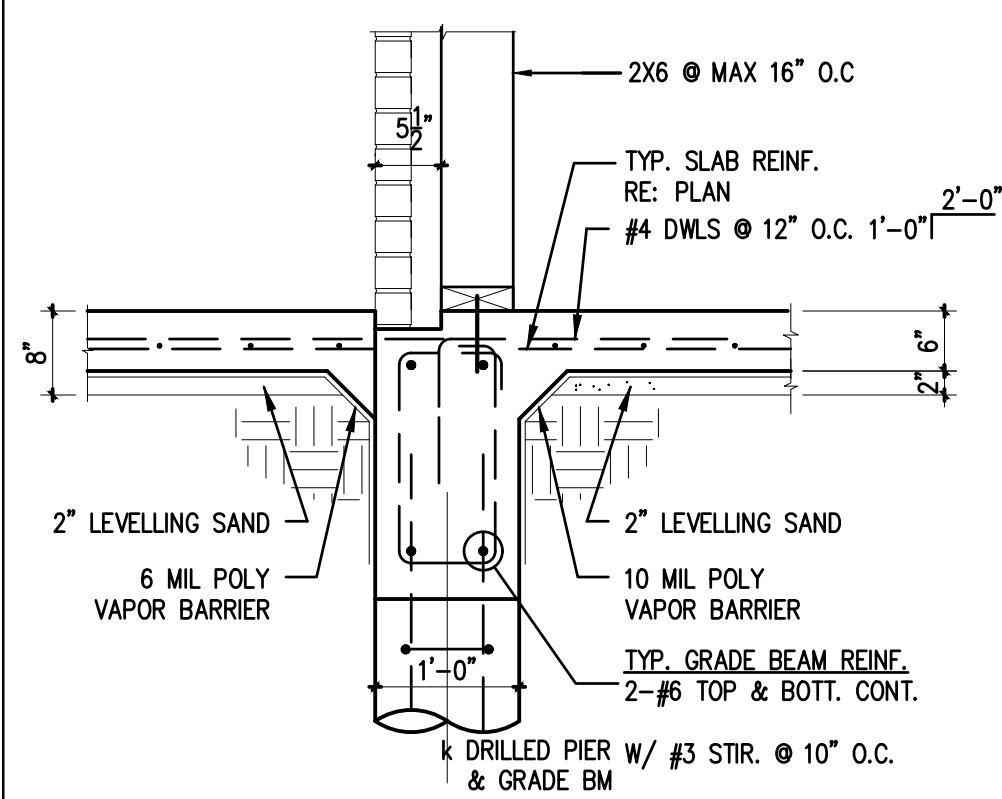

**3 SECTION: AT EXTERIOR BEAM & WALL**

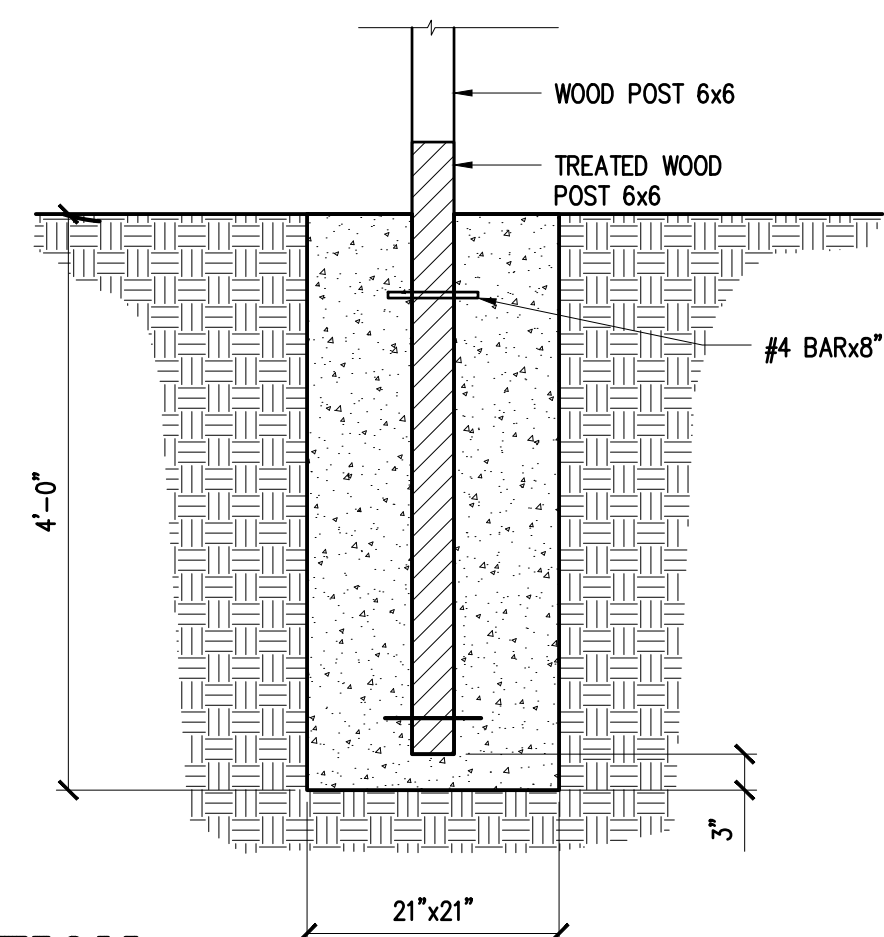

**4 SECTION: PERGOLA POST FOUNDATION DETAIL**

**WALL DETAILS**

- 2x6 STUD @ 16"
- 5/8" PLYWOOD ON EXTERIOR FACE OF WALLS
- ROOF DECK 5/8" PLYWOOD EXTERIOR GRADE

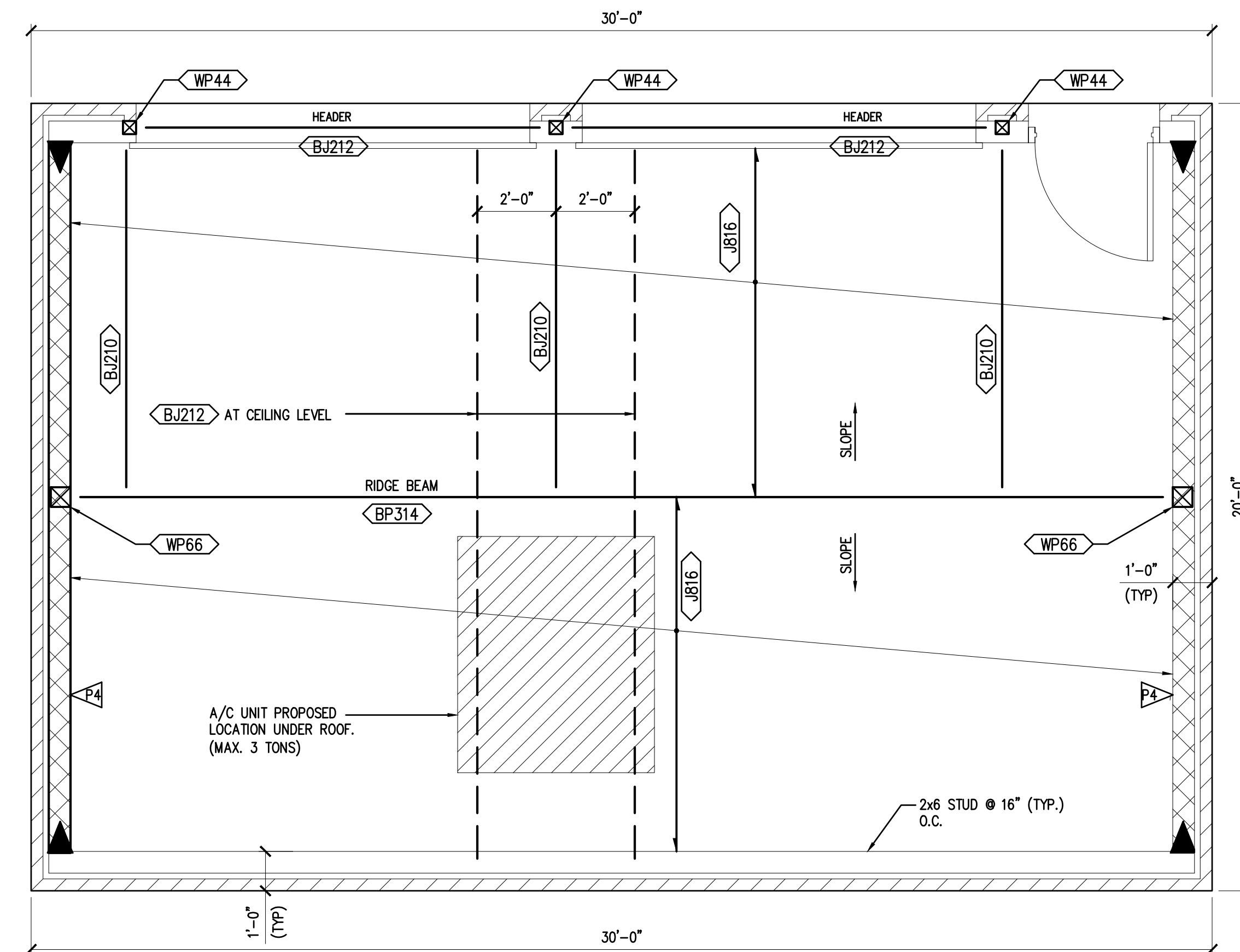

**GARAGE ROOF FRAMING PLAN**  
SCALE: 3/8" = 1'-0"

**GARAGE FOUNDATION & ROOF FRAMING**

**OPTIMUM PERSONAL CARE PH.2**

1110 LAKEVIEW DRIVE  
SUGAR LAND, TX. 77478

**ISSUE HISTORY**

DATE	ISSUED FOR
	CLIENT REVIEW
	PERMIT
	CONSTRUCTION

09/10/15



**PE** BUILDINGS  
BRIDGES  
INSPECTIONS  
MARINE STRUCTURES  
CIVIL ENGINEERING &  
STRUCTURAL ENGINEERING

**PARAMOUNT ENGINEERING LLC**

10145 LONG POINT DR.  
HOUSTON, TX 77043  
TEL: (713) 636-9977  
FAX: (713) 888-9872  
CEL: (713) 204-1742

TBPE REGISTRATION # F-3394

DRAWN BY: E.V. CHECKED BY: M.M.

PROJ. NO.: PE12-225

SHEET: **S9**

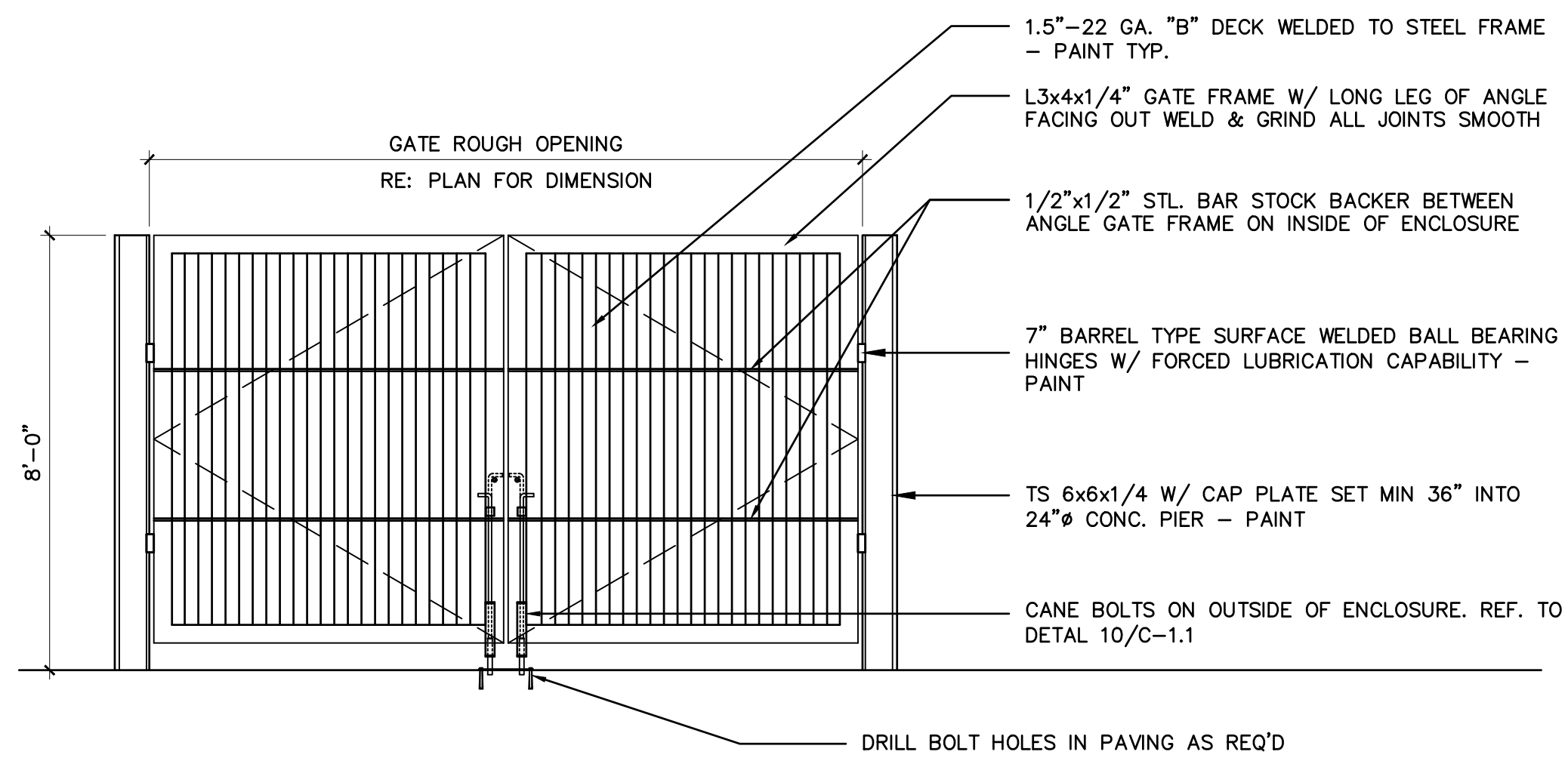

**1 TRASH ENCLOSURE GATE ELEV.**  
SCALE: 3/8" = 1'-0"

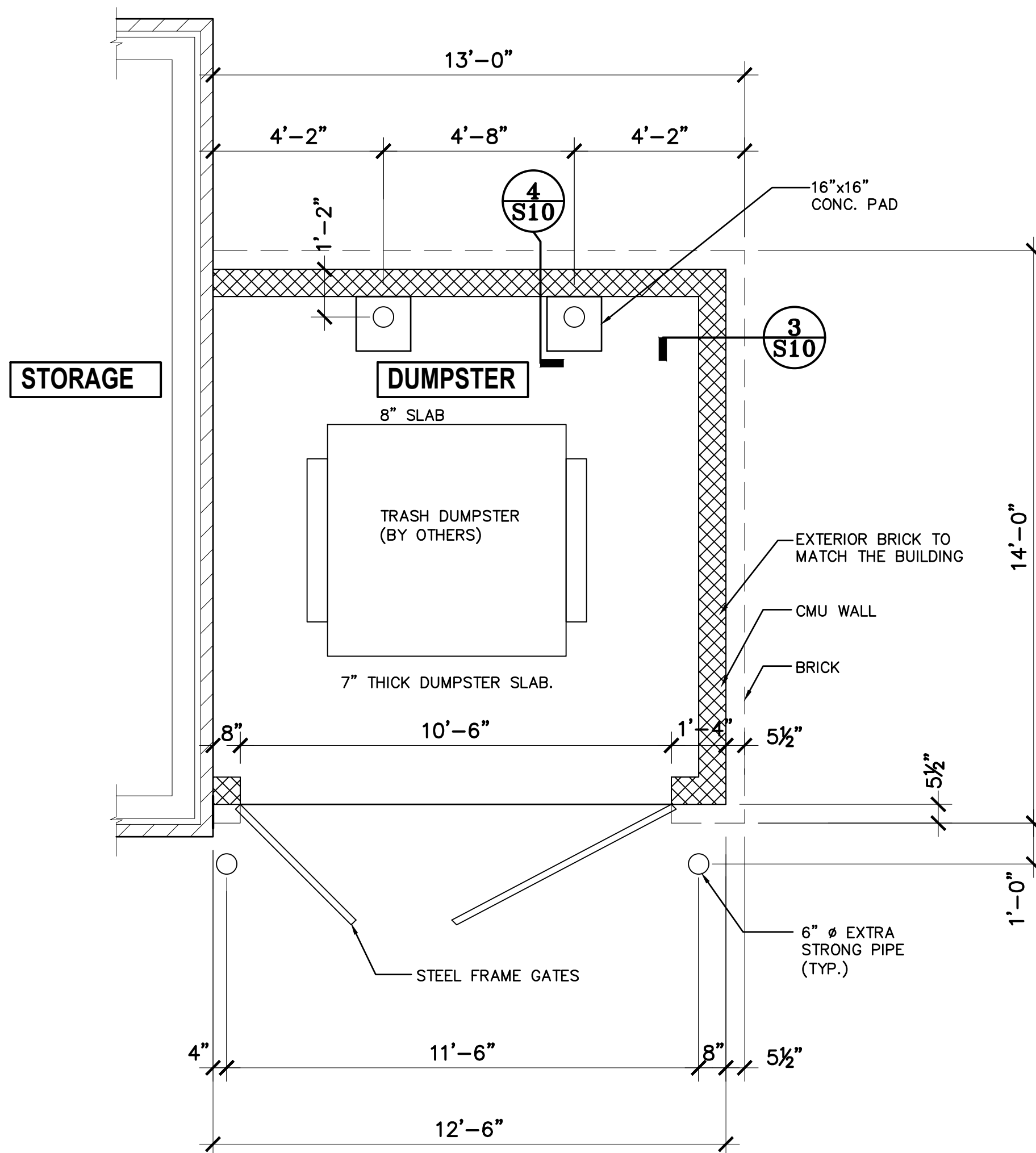

**2 TRASH ENCLOSURE PLAN**  
SCALE: 3/8" = 1'-0"

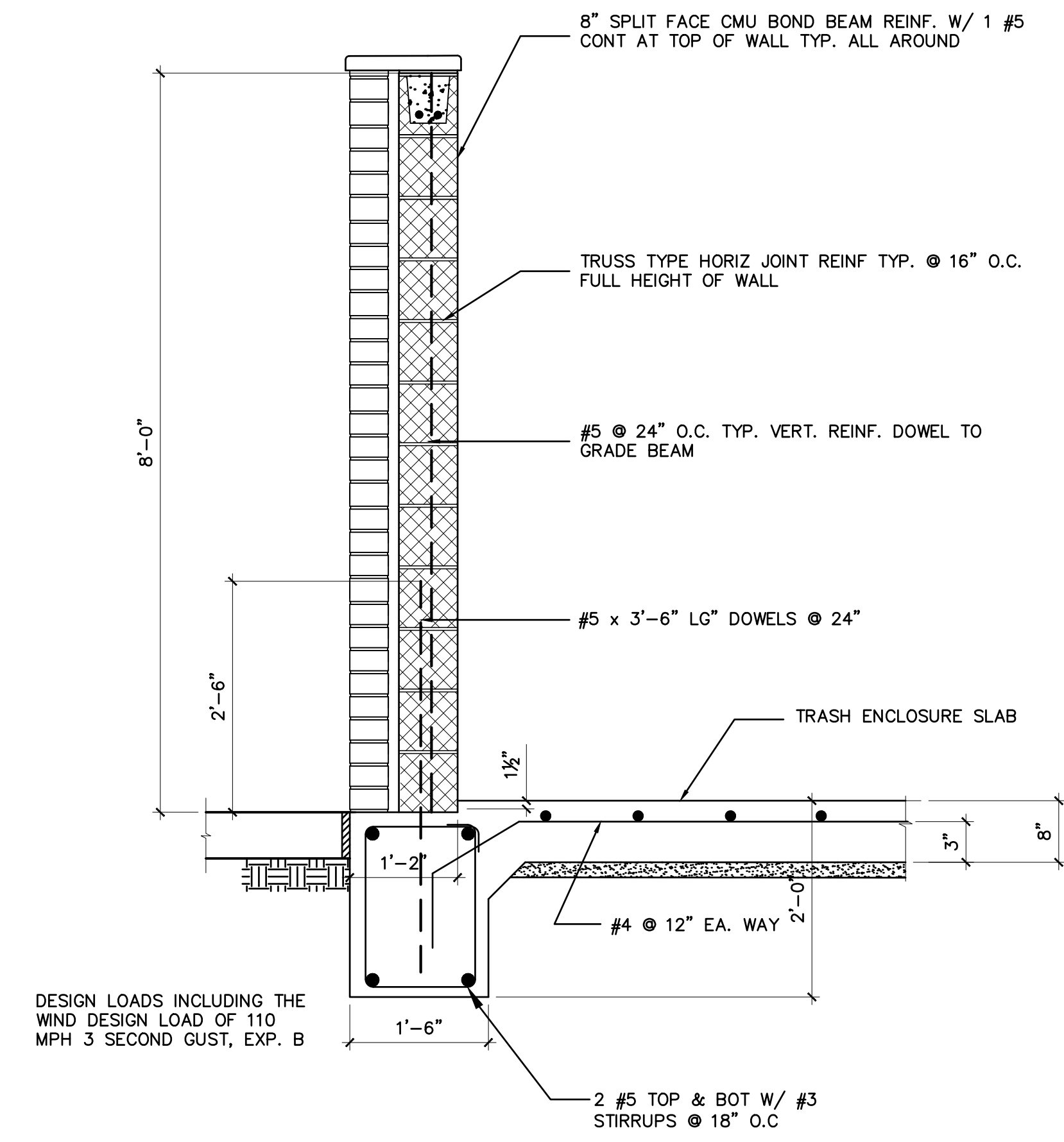

**3 TRASH ENCLOSURE WALL/ FOUNDATION**  
SCALE: 3/4" = 1'-0"

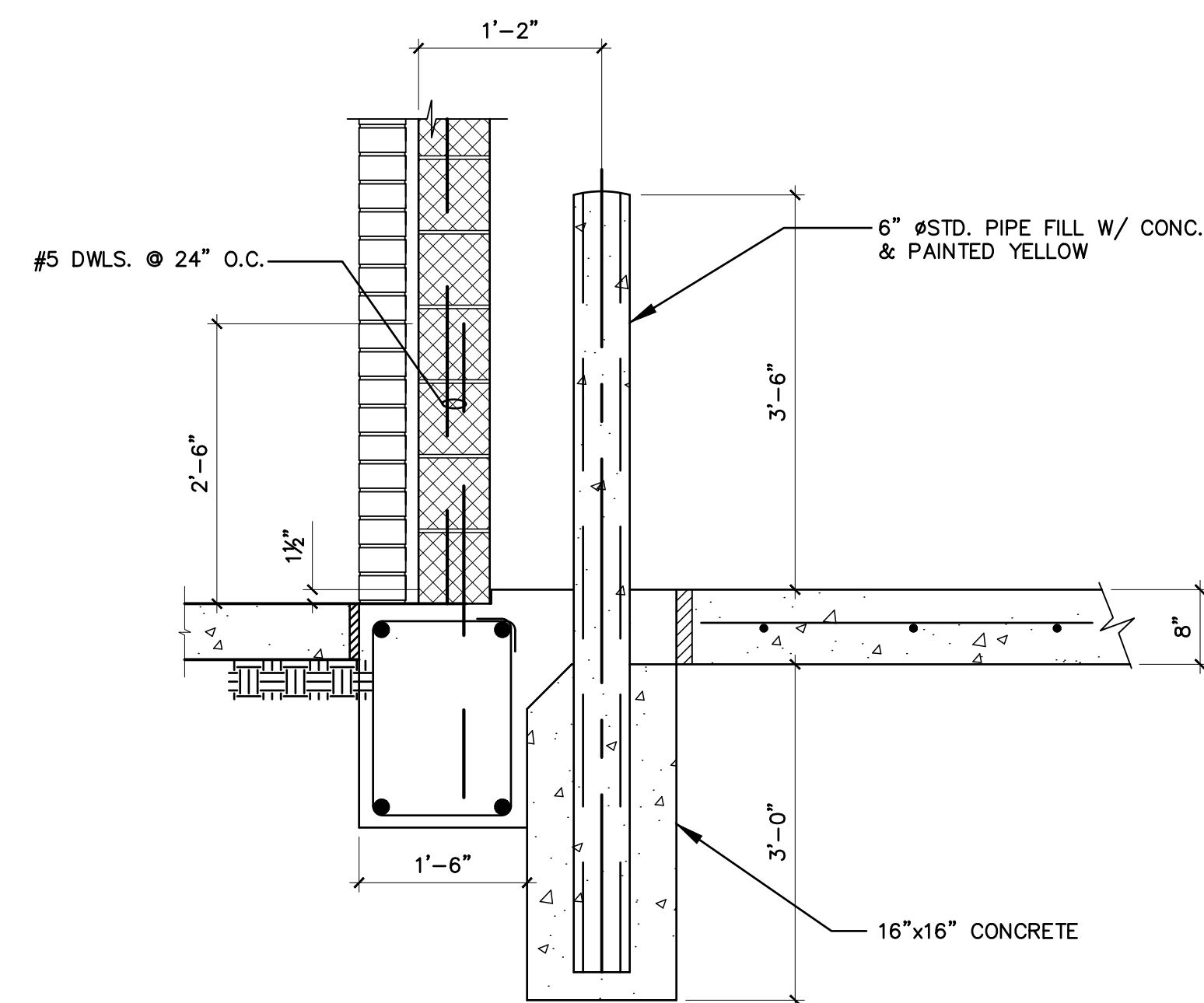

**5 SECTION: TYP. BOLLARD DETAIL**  
SCALE: 3/4" = 1'-0"

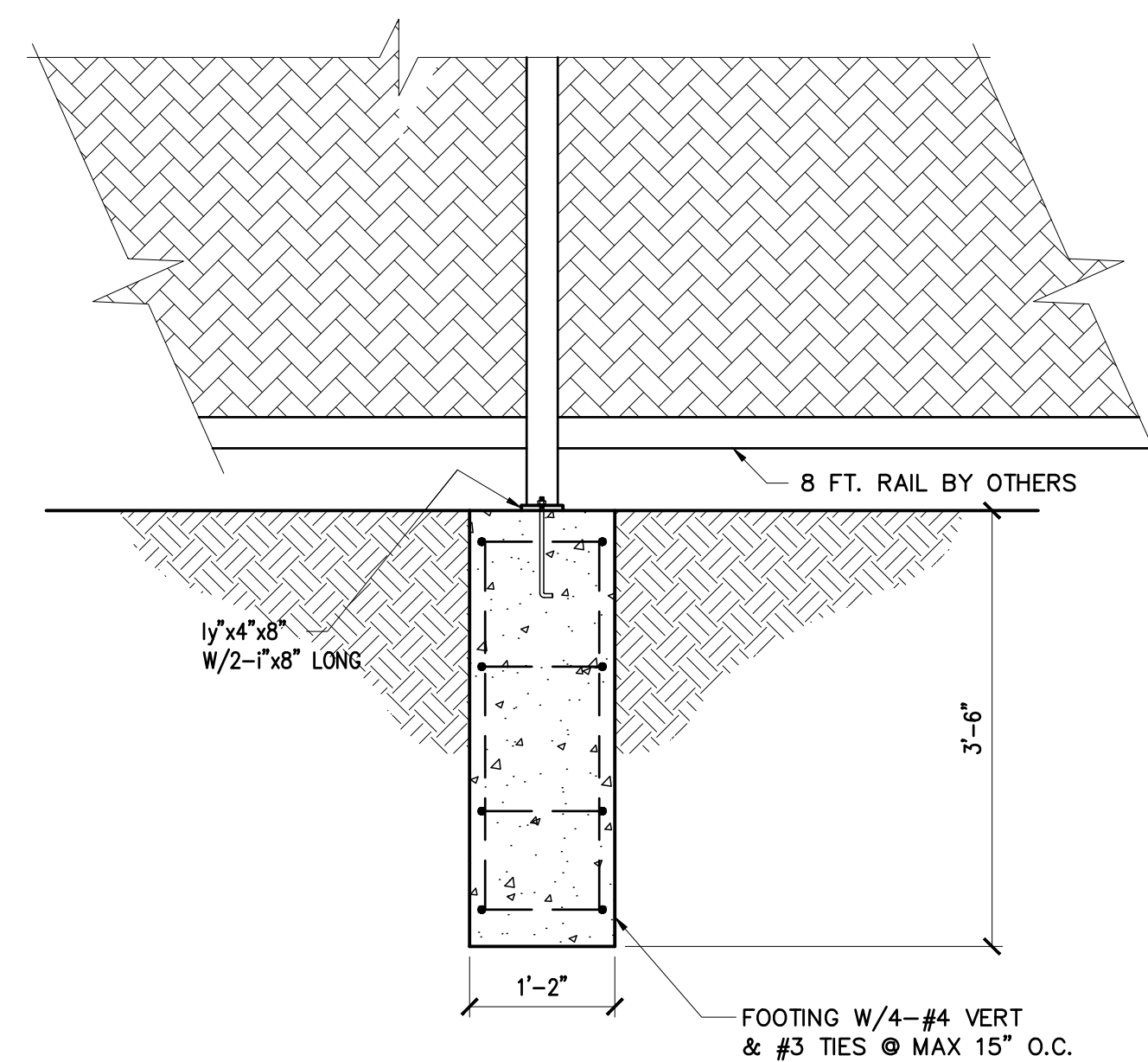

**6 SECTION: FENCE POST FOUNDATION**  
SCALE: 3/4" = 1'-0"

**4 SECTION:**  
SCALE: 3/4" = 1'-0"

**GARAGE & DUMPSTER FOUNDATION**

**OPTIMUM PERSONAL CARE PH.2**

1110 LAKEVIEW DRIVE  
SUGAR LAND, TX. 77478

ISSUE HISTORY	
DATE	ISSUED FOR
	CLIENT REVIEW
	PERMIT
	CONSTRUCTION

09/10/15

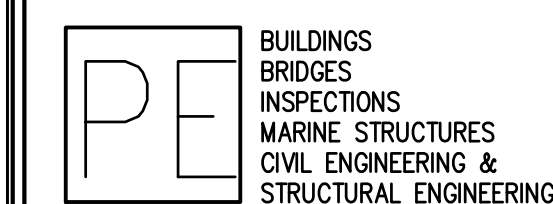

**PARAMOUNT ENGINEERING LLC**

10145 LONG POINT DR.  
HOUSTON, TX 77043

TEL : (713) 636-9977  
FAX : (713) 888-9872  
CEL : (713) 204-1742

TBPE REGISTRATION # F-3394

DRAWN BY: E.V. CHECKED BY: M.M.

PROJ. NO.: PE12-225

SHEET: **S10**

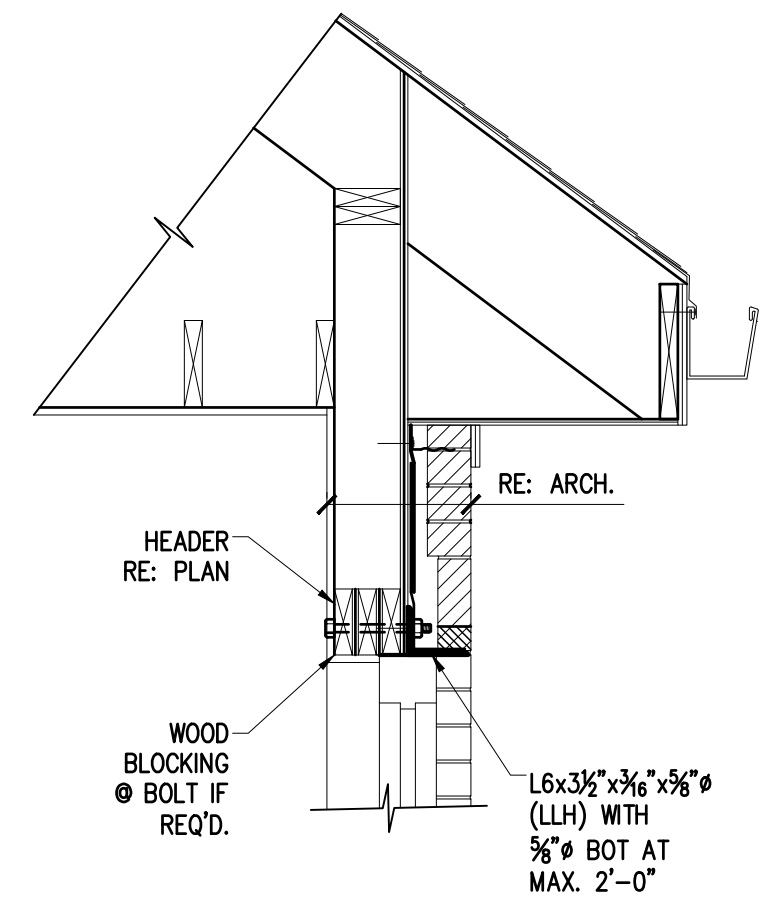

1 DETAIL: AT DOOR LINEL

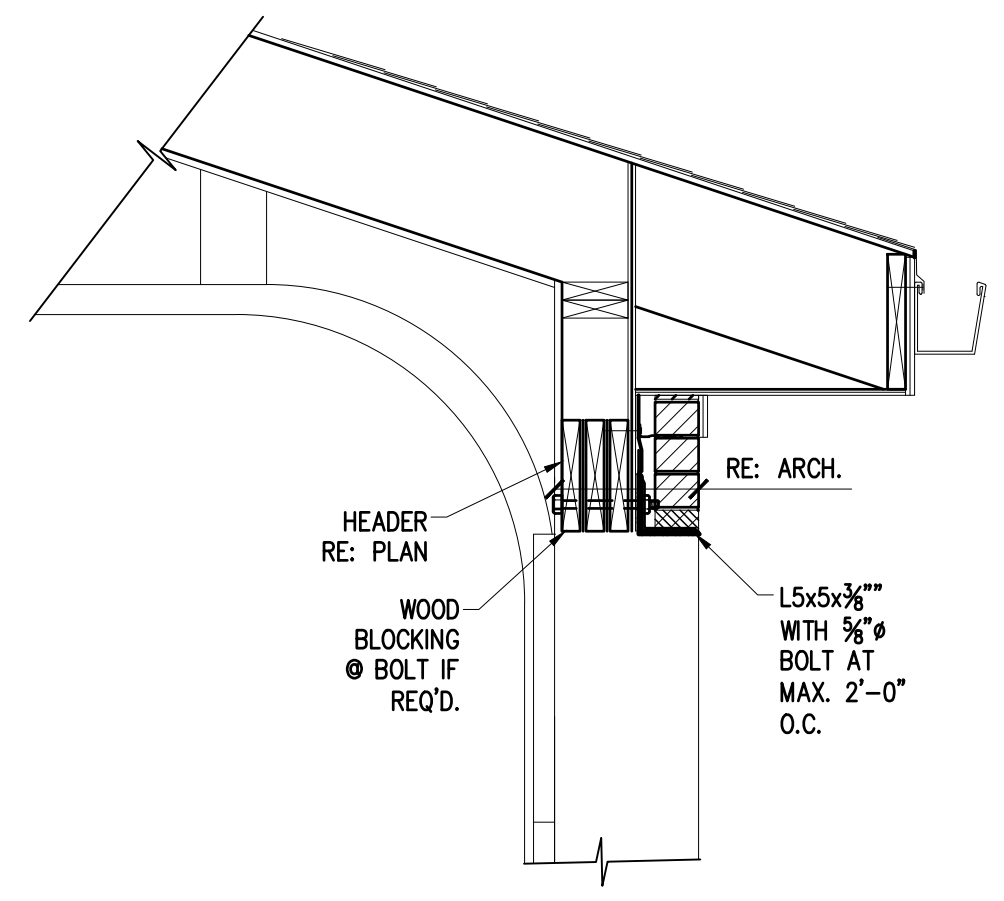

2 DETAIL: AT GARAGE LINEL

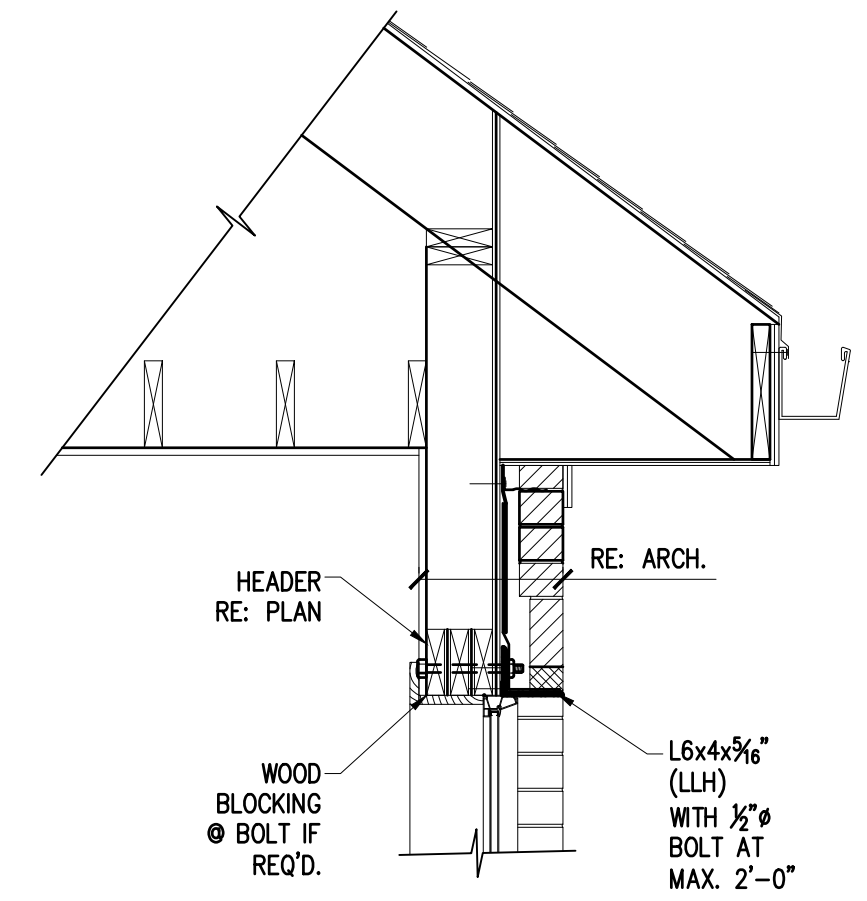

3 DETAIL: AT WINDOW LINEL

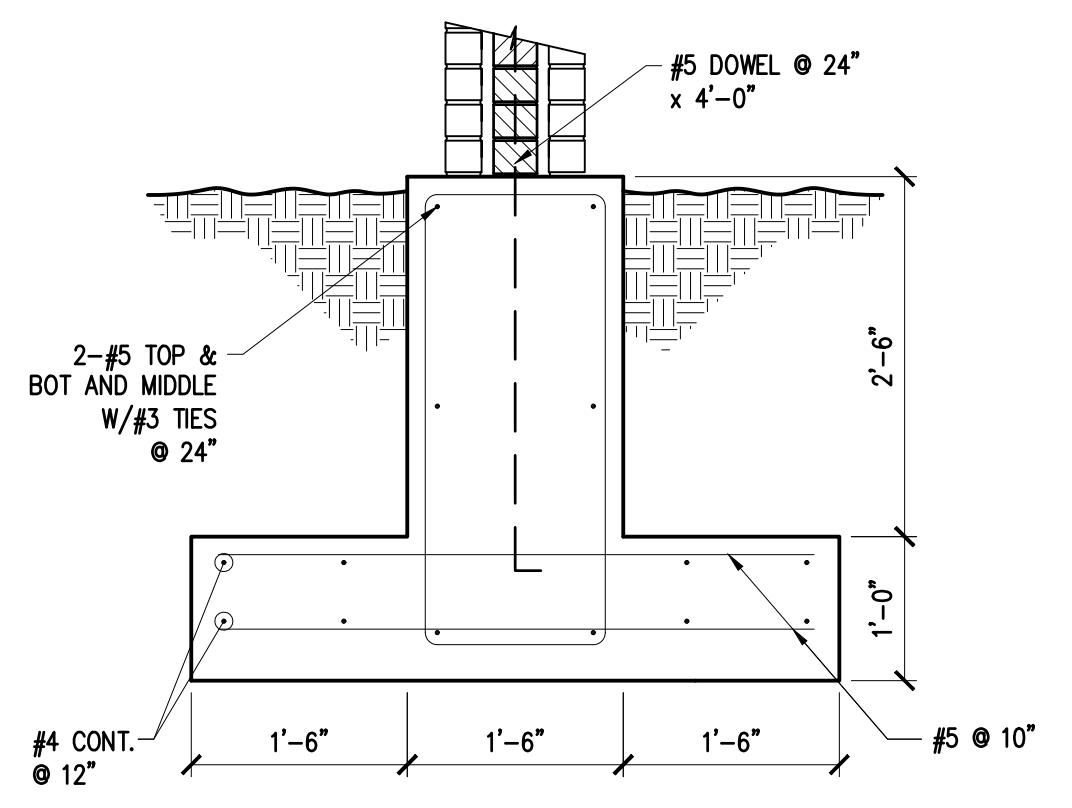

1 SECTION: GATE WALL FOUNDATION DETAIL

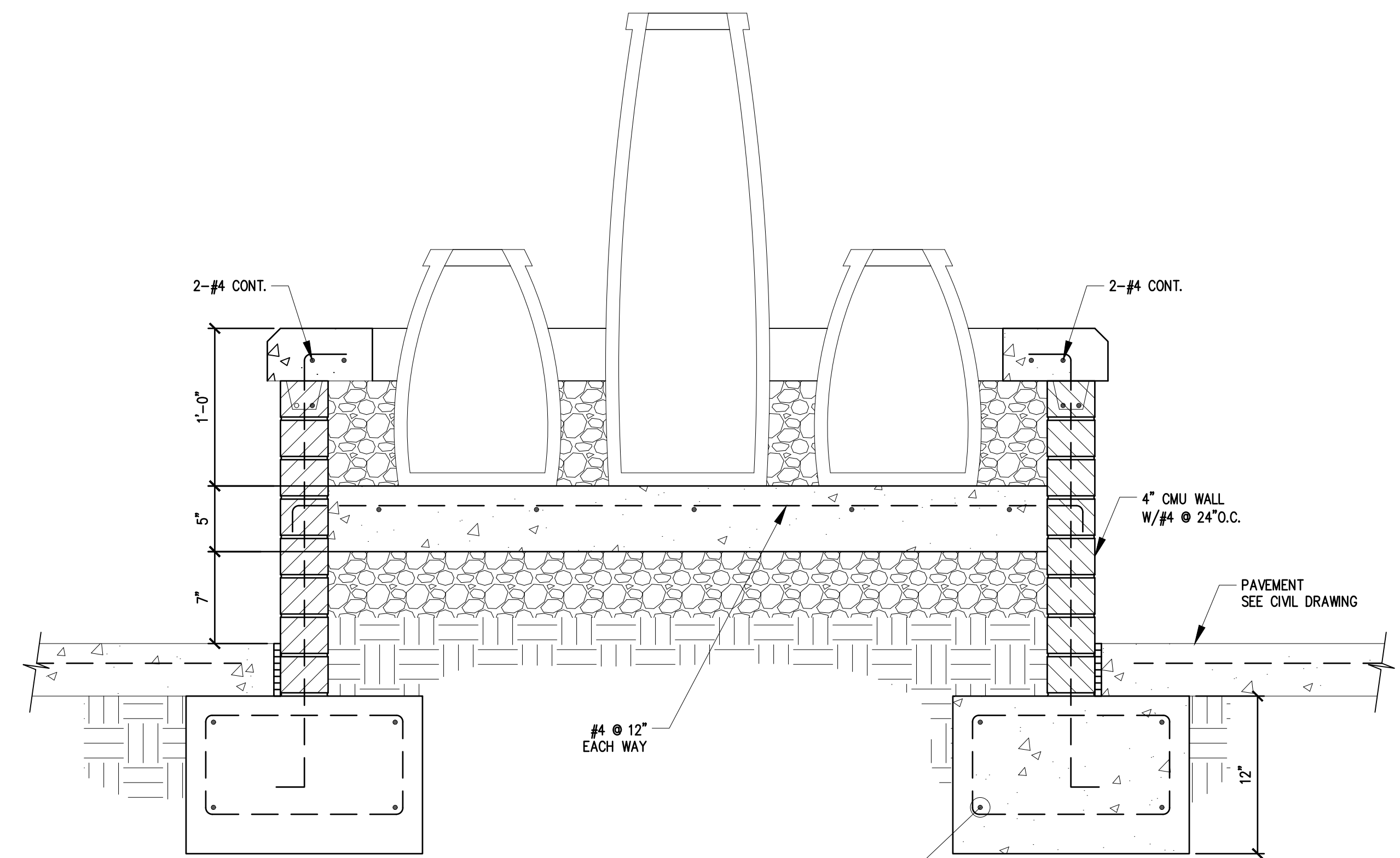

FOUNDATION AT FOUNTAIN  
SCALE: 1 1/2" = 1'-0"

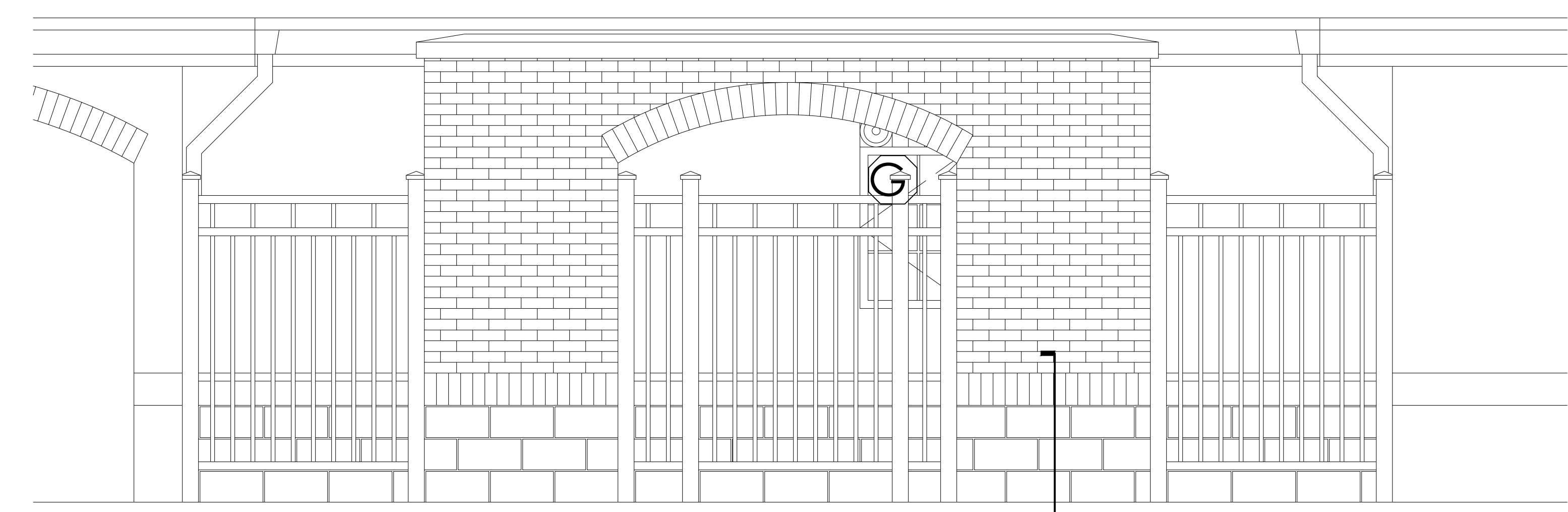

GATE ENTRANCE ELEVATION/FOUNDATION  
SCALE: 1 1/2" = 1'-0"

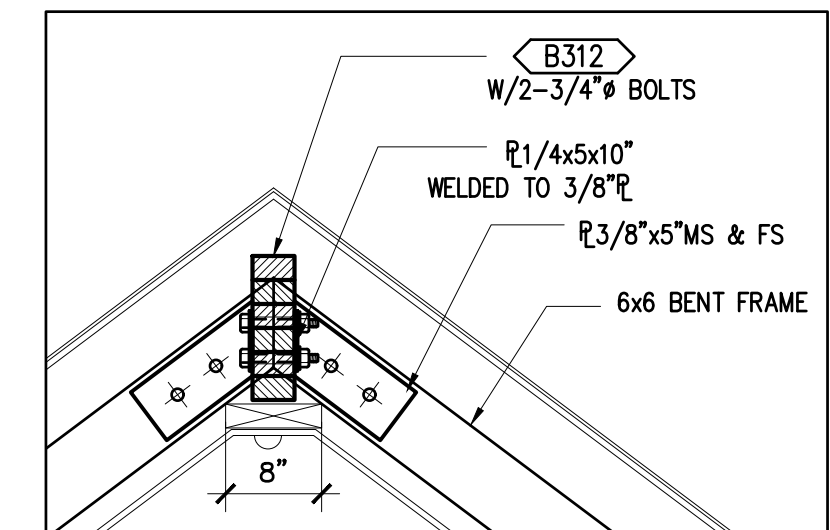

DETAIL A  
SCALE: 3/4" = 1'-0"

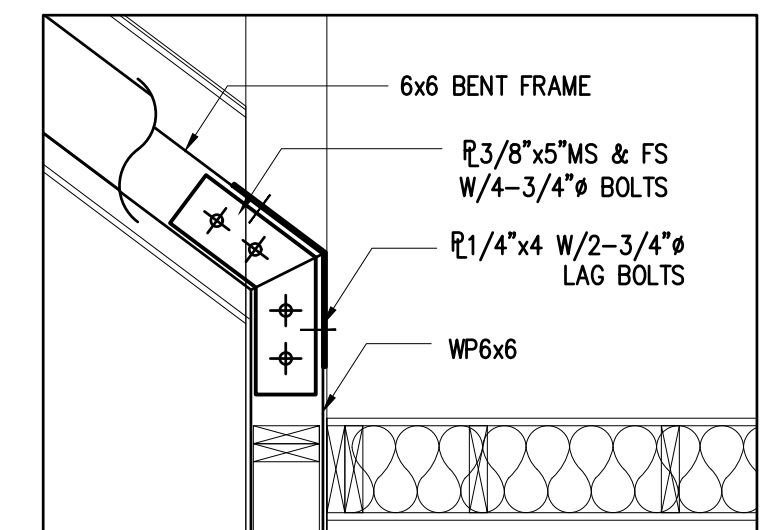

DETAIL B  
SCALE: 3/4" = 1'-0"

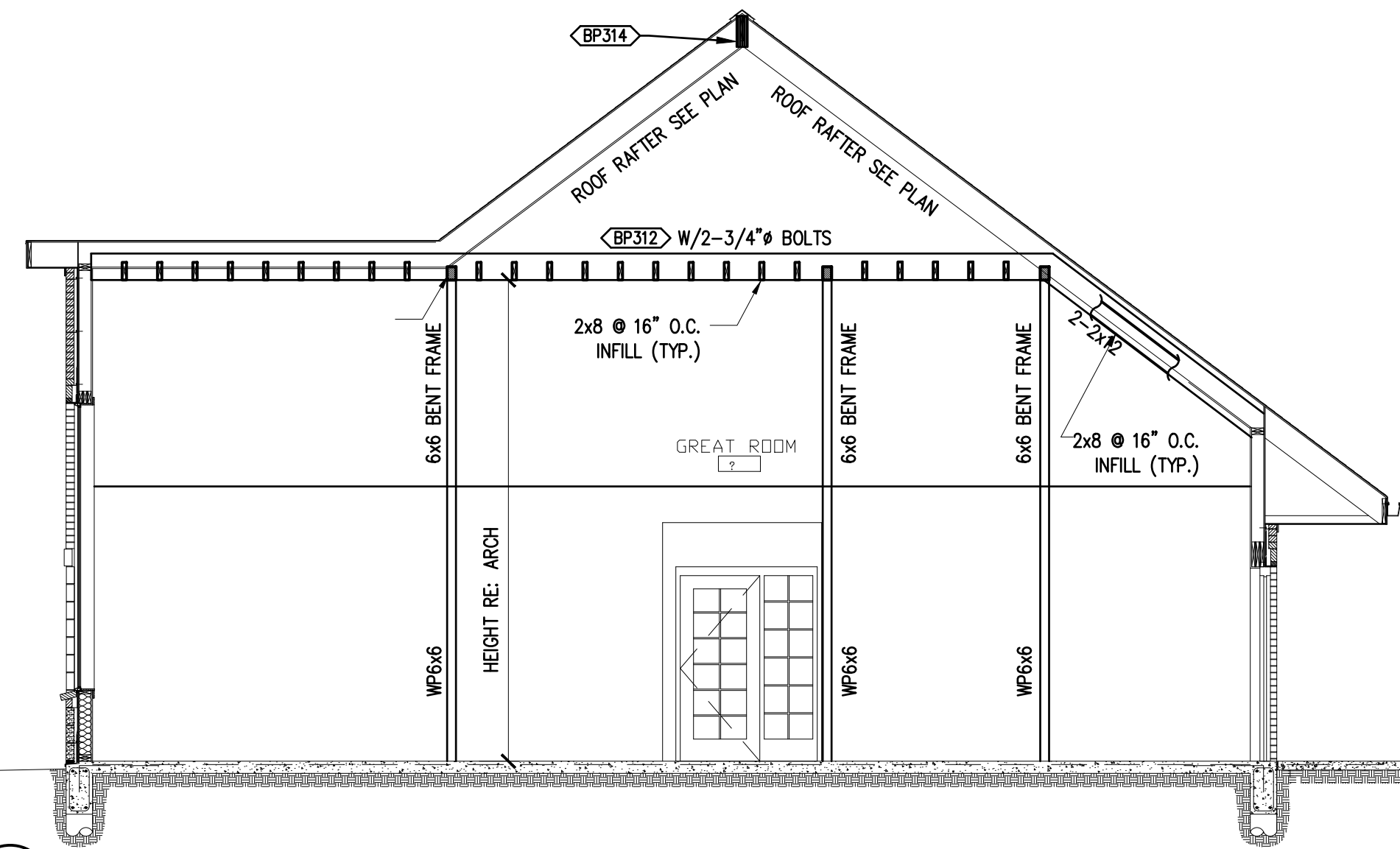

2 SECTION: AT GREAT ROOM

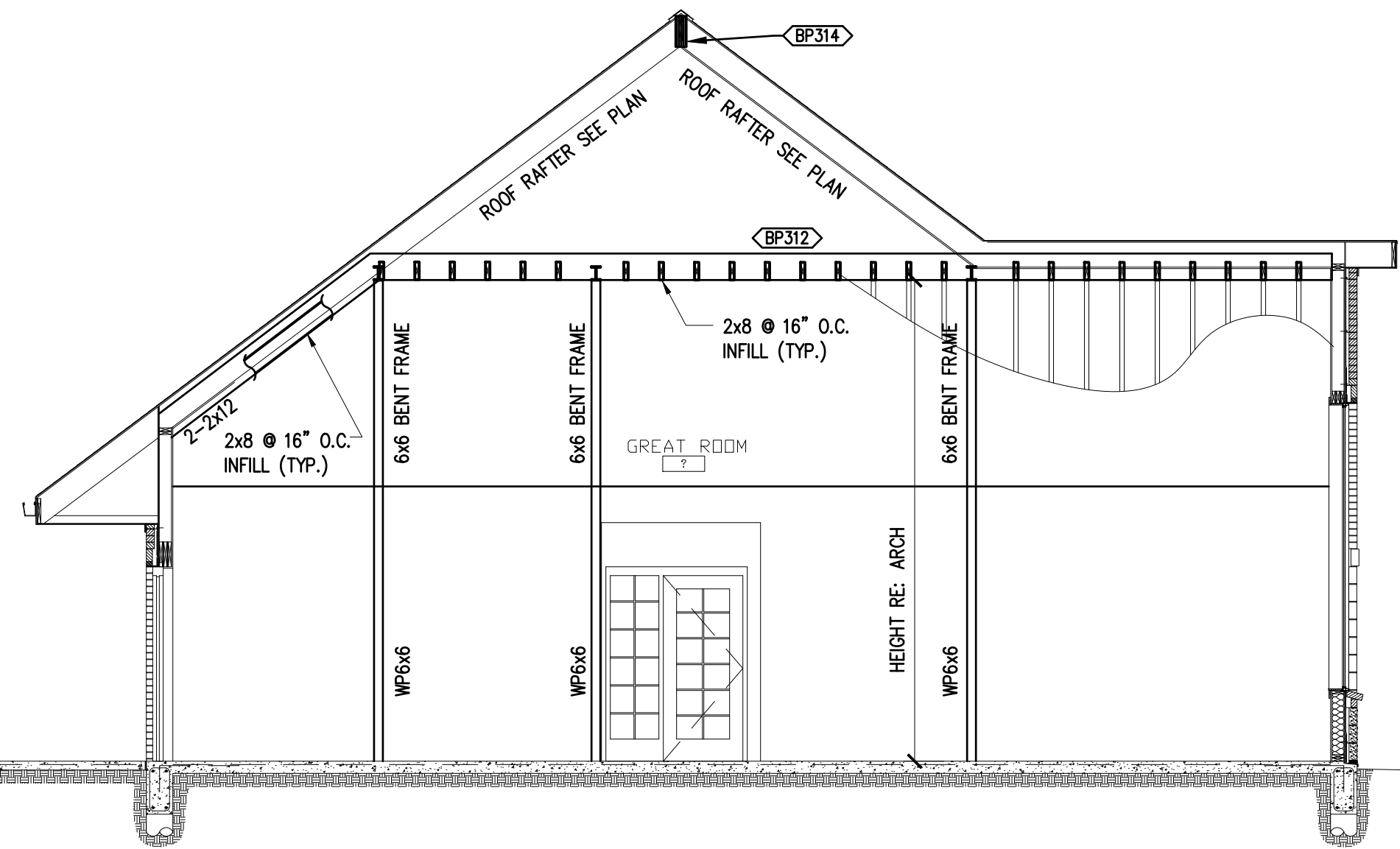

3 SECTION: AT GREAT ROOM

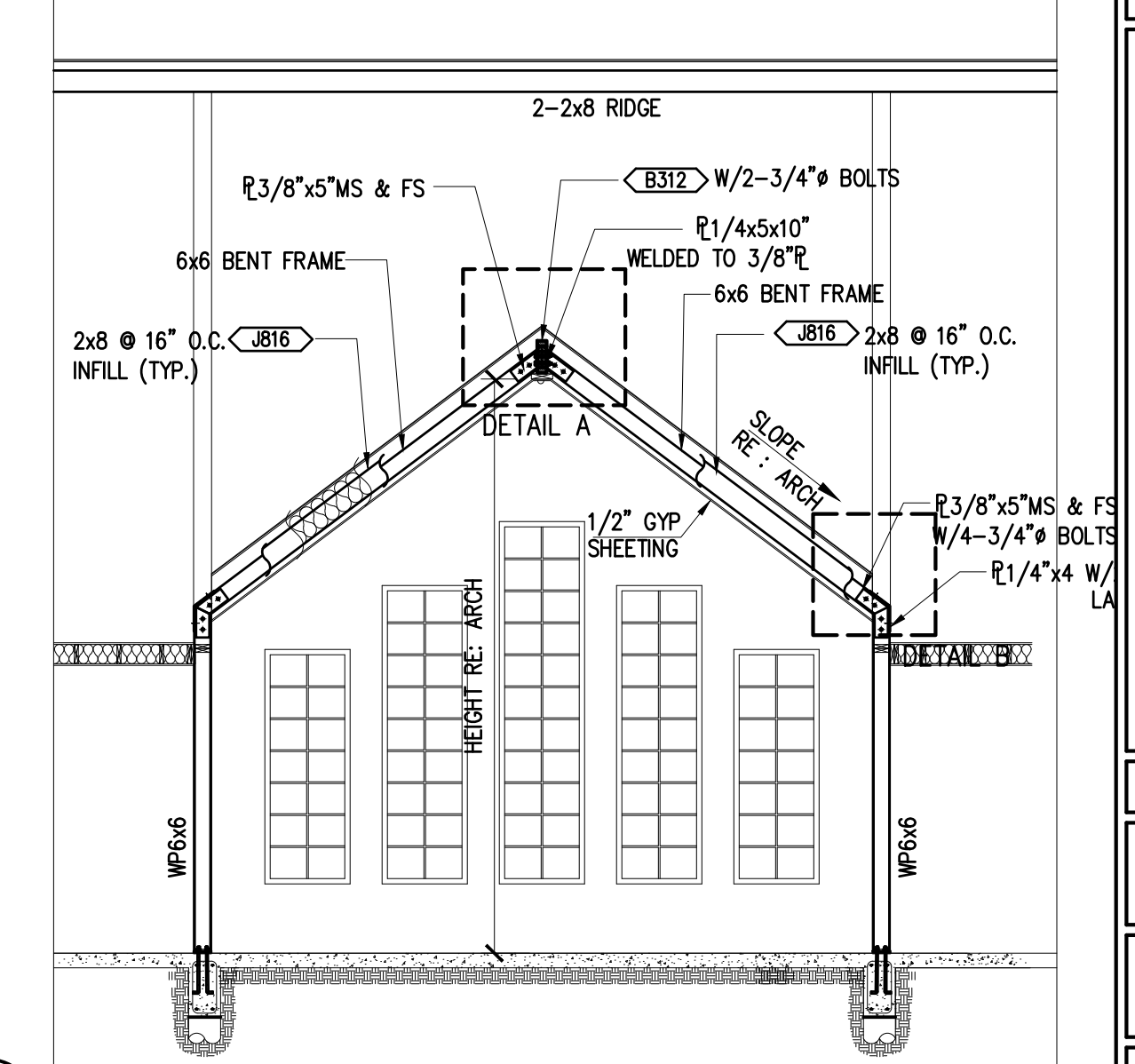

4 SECTION: AT GREAT ROOM

LINTEL  
DETAILS  
&  
FOUNDATION  
SECTIONS

OPTIMUM PERSONAL CARE PH.2  
1110 LAKEVIEW DRIVE  
SUGAR LAND, TX. 77478

ISSUE HISTORY	
DATE	ISSUED FOR
	CLIENT REVIEW
	PERMIT
	CONSTRUCTION

09/10/15

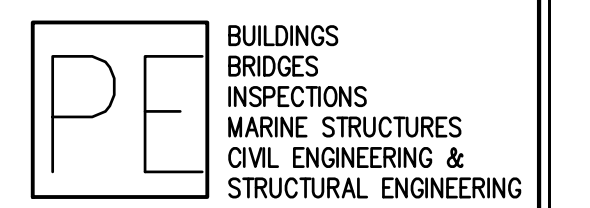

PARAMOUNT  
ENGINEERING  
LLC

10145 LONG POINT DR.  
HOUSTON, TX 77043  
TEL: (713) 636-9977  
FAX: (713) 888-9872  
CEL: (713) 204-1742

TBPE REGISTRATION # F-3394  
DRAWN BY: Z.A. CHECKED BY: M.M.

PROJ. NO.: PE12-225

SHEET: S11