

- GENERAL NOTES: STRUCTURAL AND MISC. STEEL**
- CONFORM TO THE FOLLOWING MATERIAL SPECIFICATIONS:
STRUCTURAL & MISC. SHAPES: ASTM A-36
PIPE COLUMNS: ASTM A-53-B
TUBE COLUMNS: ASTM A-500-B
 - ALL DETAILING SHALL BE IN CONFORMANCE WITH THE STANDARDS OF THE AMERICAN INSTITUTE OF STEEL CONSTRUCTION (AISC).
 - UNLESS NOTED OTHERWISE, PROVIDE FRAMED BEAM CONNECTIONS IN ACCORDANCE WITH PART 4, AISC MANUAL - 3/4" ASTM A-307 BOLTS. DESIGN FOR SHEARS IN TABLES FOR ALLOWABLE LOADS ON BEAMS, PART 2.
 - FIELD CONNECTIONS SHALL BE EQUIVALENT TO STANDARD BOLTED CONNECTIONS USING 3/4" ASTM A-307 BOLTS UNLESS OTHERWISE SHOWN. IF CONNECTION BOLTS ARE IN SINGLE SHEAR, BOLTS SHALL BE PLACED IN TWO VERTICAL ROWS. CONNECTIONS SHALL BE BOLTED OR WELDED - SEE DETAILS.
 - WELDING SHALL CONFORM TO THE "CODE FOR WELDING IN BUILDING CONSTRUCTION" BY THE AMERICAN WELDING SOCIETY, LATEST EDITION. WELDS NOT CALLED OUT ON DRAWINGS SHALL BE 1/4" CONTINUOUS FILLET WELDS. WELDING ELECTRODES SHALL CONFORM TO AWS A5.1 OR A5.5 E70XX.
 - ALL WELDING SHALL PERFORMED BY CERTIFIED WELDERS.
 - ANCHOR BOLTS SHALL CONFORM TO ASTM A-307 FOR HEADED A.B. AND A-36 FOR UNHEADED AND HOOKED A.B., AND SHALL BE SET USING RIGID TEMPLATES.
 - PROVIDE TEMPORARY BRACING & SHORING FOR ALL STEEL FRAMING AS REQ'D TO ENSURE STABILITY DURING CONSTRUCTION.
NOTE THAT STEEL FRAMING MEMBERS MAY NOT BE STABLE DURING CONSTRUCTION UNTIL PERMANENTLY CONNECTED WITHIN THE OVERALL STRUCTURE.
 - IT IS THE RESPONSIBILITY OF THE CONTRACTOR TO VERIFY ALL DIMENSION, ELEVATION AND REVIEW THESE DRAWINGS BEFORE FABRICATION OR ORDERING MATERIALS.

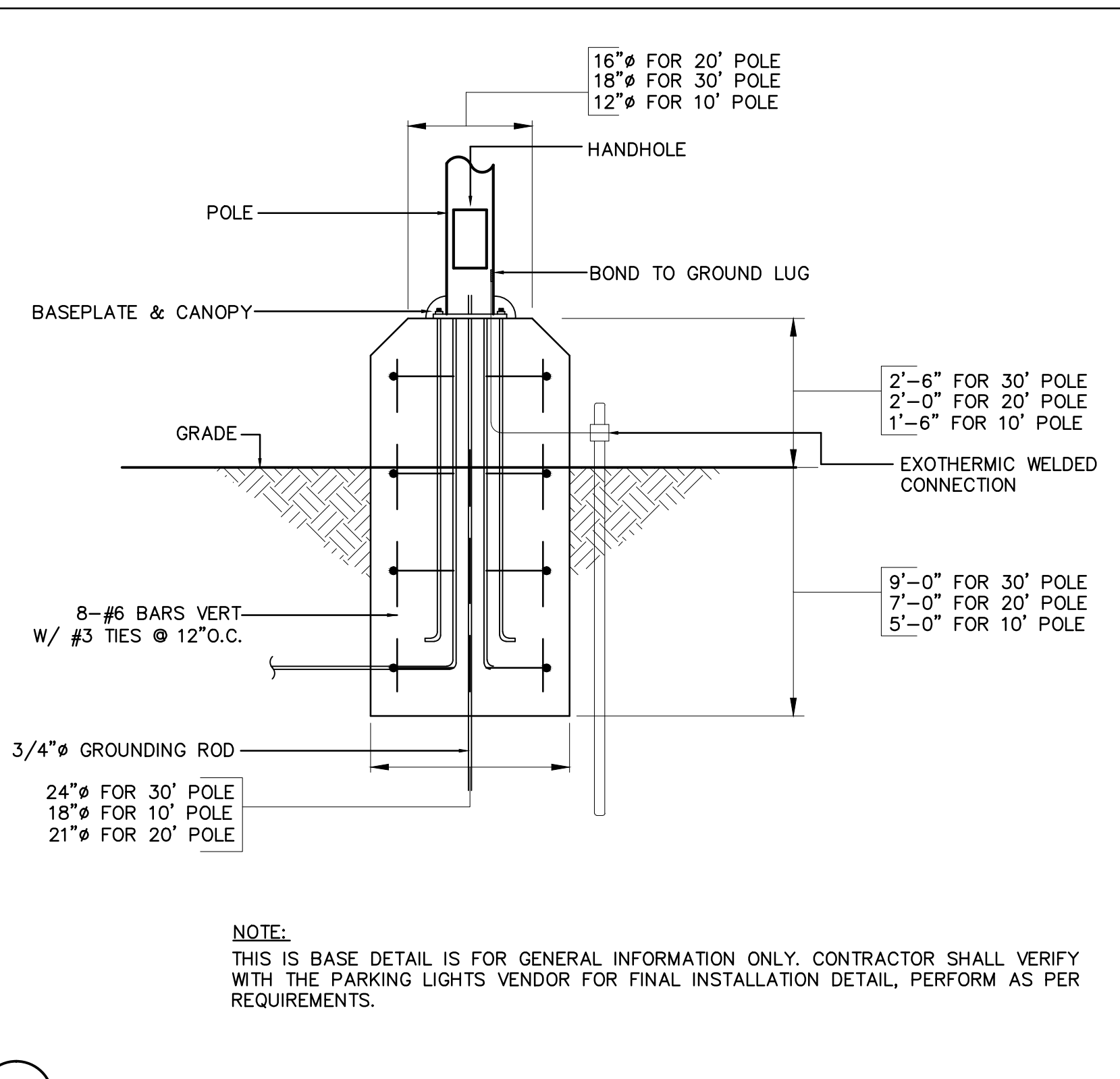
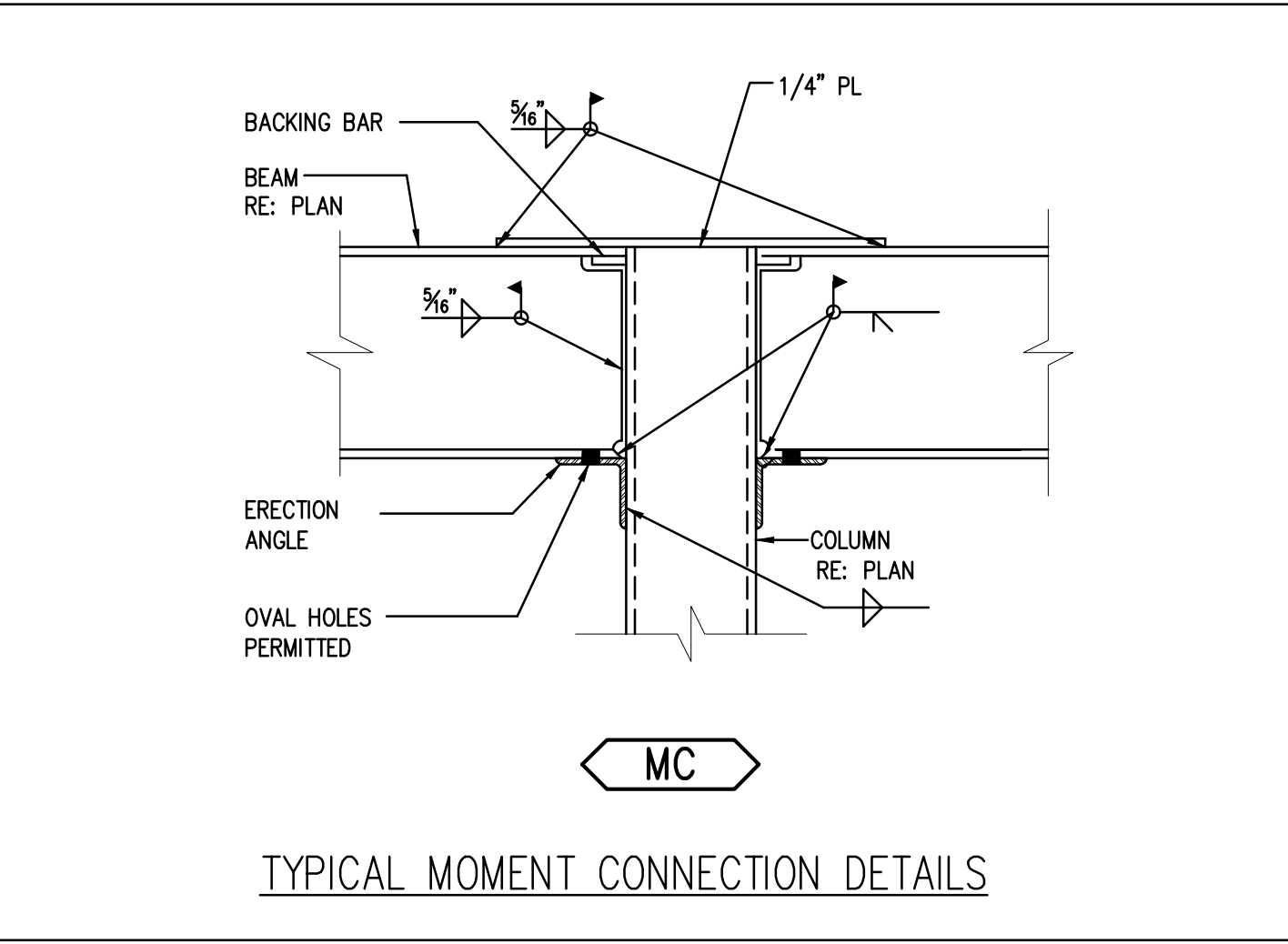
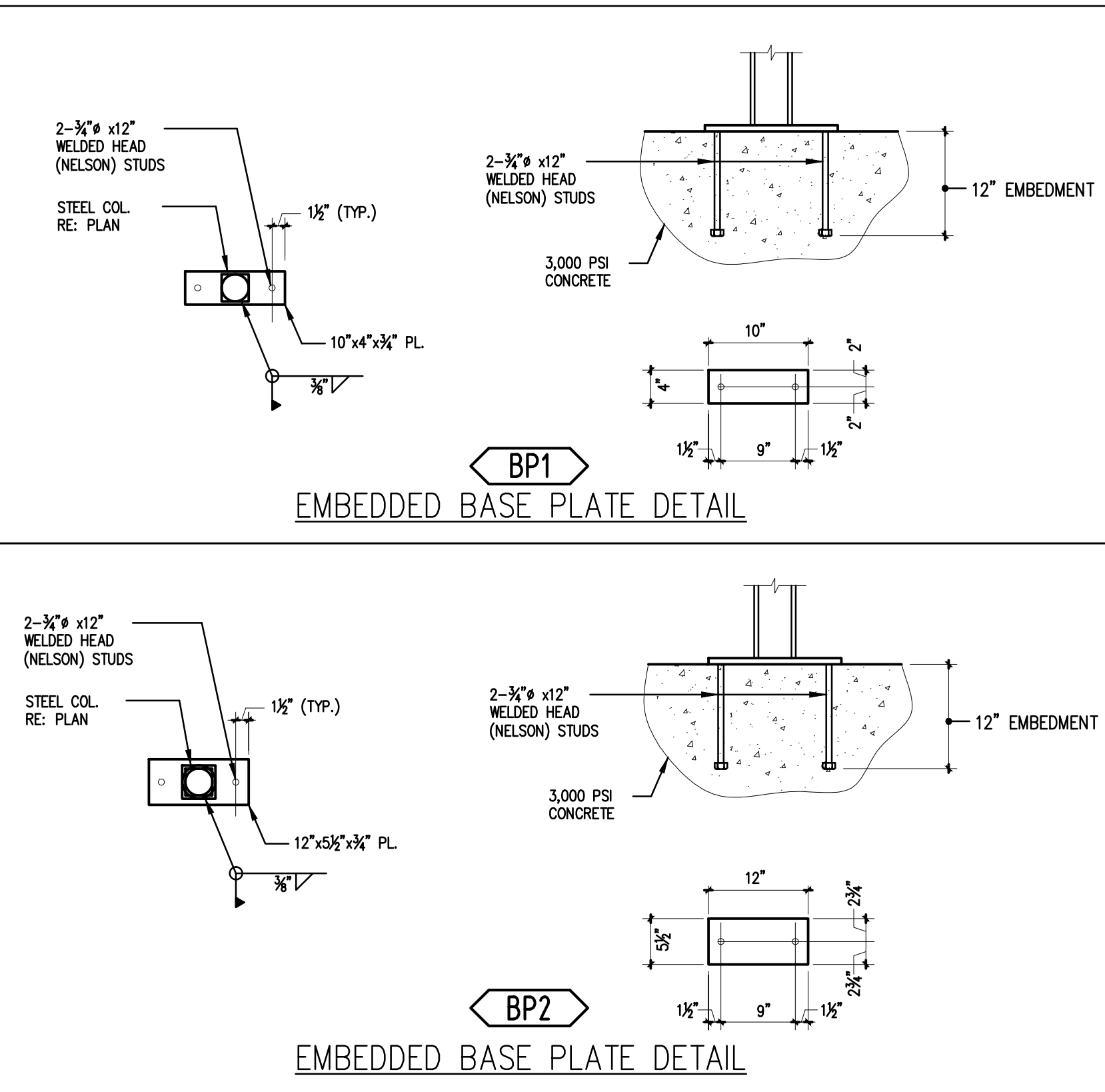
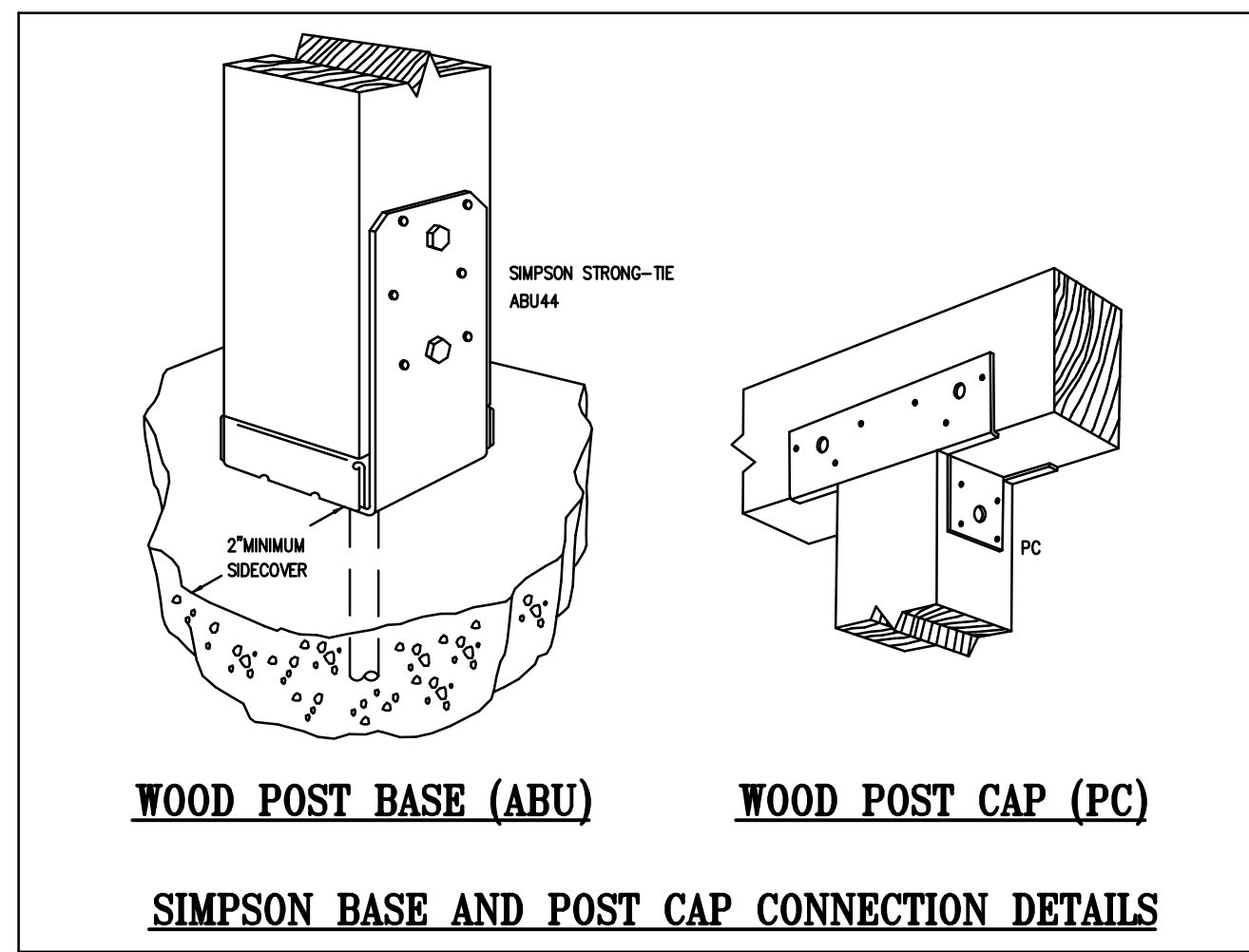
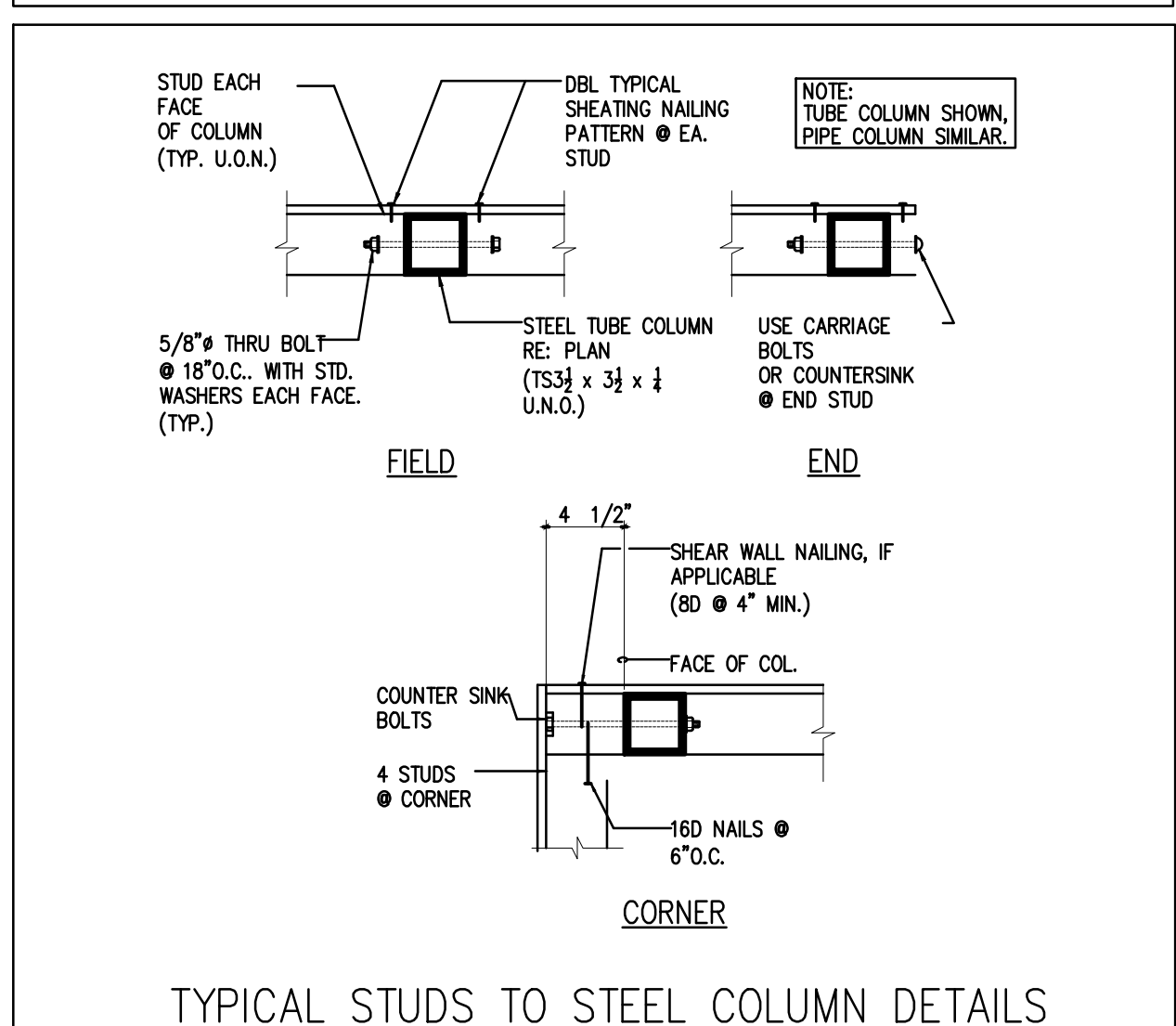
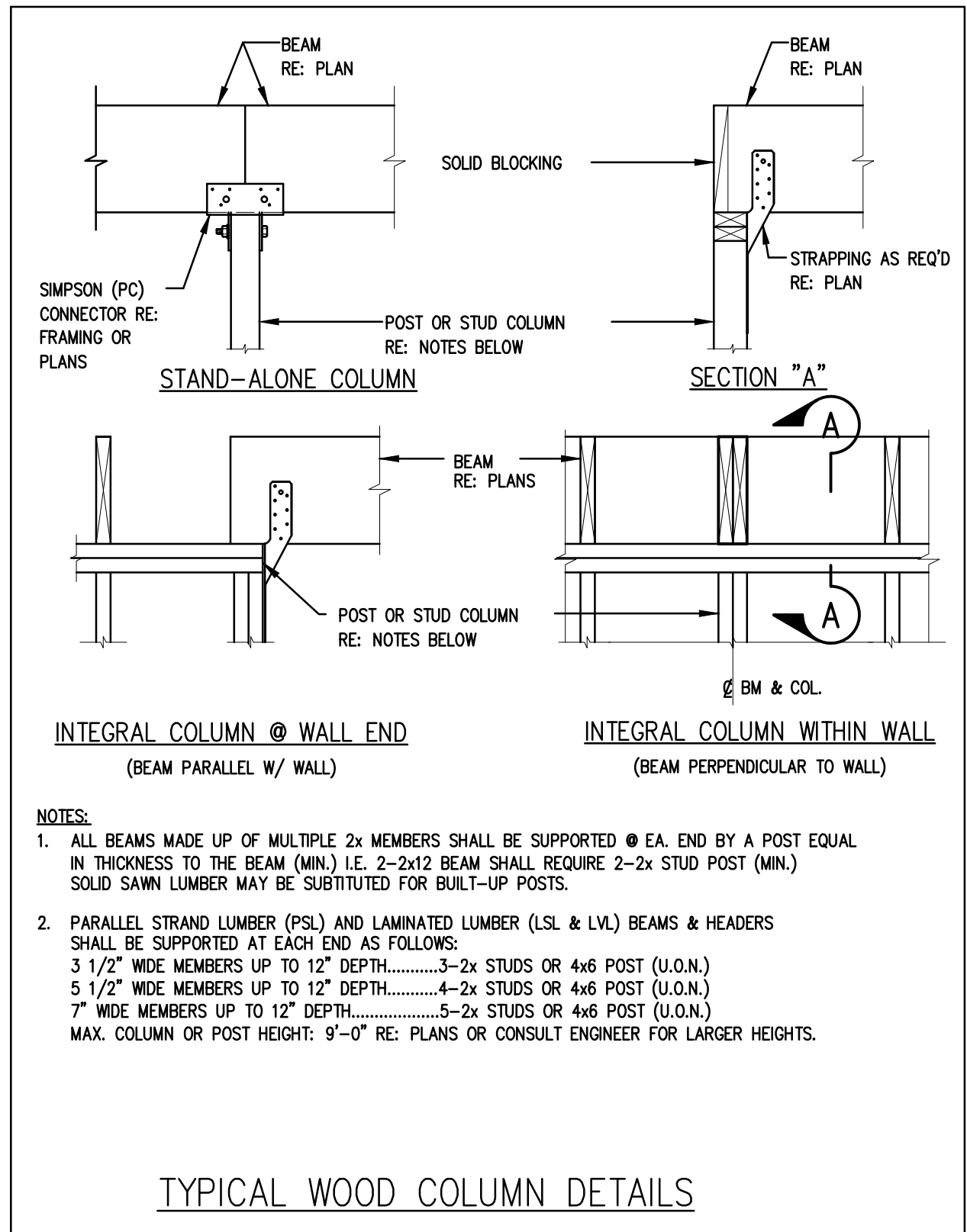

GENERAL NOTES

OPTIMUM PERSONAL CARE
1110 LAKEVIEW DRIVE
SUGAR LAND, TX. 77478

ISSUE HISTORY

DATE	ISSUED FOR
	CLIENT REVIEW
	PERMIT
	CONSTRUCTION

10/25/13

Z:\SEAL.jpg

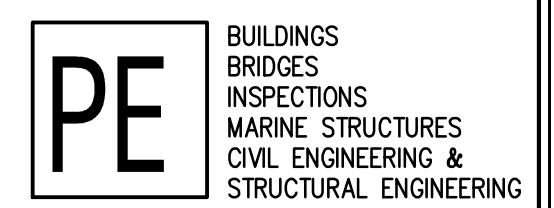

PARAMOUNT ENGINEERING LLC

7322 SOUTHWEST FREEWAY STE. 1050
HOUSTON, TX 77074
TEL : (713) 636-9977
FAX : (713) 888-9872
CEL : (713) 204-1742

TBPE REGISTRATION # F-3394

DRAWN BY: E.V. CHECKED BY: M.M.

PROJ. NO.: PE12-225

SHEET: **S8**